

CATALOGO REV.2 MARZO 2025

DOMINUS SERRANDE / ROLLING SHUTTERS



FERRARO
UNA PORTA SUL FUTURO

LA SERRANDA THE ROLLING SHUTTER	2
PRODOTTI CONSIGLIATI RECOMMENDED PRODUCTS	4
PROGETTIAMO CON LO SGUARDO RIVOLTO AL FUTURO WE DESIGN LOOKING TOWARDS THE FUTURE	6
LIVING & TIME RESIDENTIAL & INDUSTRIAL DOORS	8
LA SERRANDA RESIDENZIALE LIVING LIVING RESIDENTIAL ROLLING SHUTTER	10
LA SERRANDA INDUSTRIALE TIME TIME INDUSTRIAL ROLLING SHUTTER	12
SERRANDA MONOLAMIERA SINGLE-SKINNED ROLLING SHUTTER	14
SERRANDA SFLUX SFLUX ROLLING SHUTTER	26
SERRANDA ANTITEMPESTA WINDPROOF ROLLING SHUTTER	34
SERRANDA INOX INOX ROLLING SHUTTER	40
SERRANDA IMPACCHETTABILE ROLL-PACK ROLLING SHUTTER	44
SERRANDA COIBENTATA ROLLING SHUTTER WITH POLYURETHANE INSULATION	58
SERRANDA VELOCE HIGH SPEED ROLLING SHUTTER	66
ACCESSORI ACCESSORIZES	70
AUTOMAZIONI LIVING COASSIALI LIVING COAXIAL MOTORIZATIONS	82
AUTOMAZIONI TIME LATERALI TIME SIDE MOTORIZATIONS	90
FINITURE E COLORI FINISHES AND COLORS	102
DISEGNI TECHNICAL DRAWINGS	110
ARMONIUM CANCELLETTI RIDUCIBILI ARMONIUM REDUCIBLE GATES	116

LA SERRANDA

THE ROLLING SHUTTER

La serranda caratterizza da tempo l'estetica esterna di case, edifici e negozi; è difficile trovare validi sostituti che posseggano tutte le sue caratteristiche:

The shutter has long characterized the exterior of houses, buildings and shops; it's difficult to find valid substitutes possessing all its features:

- **Struttura semplice, robusta e flessibile**
- **Meccanismo di avvolgimento salvaspazio**
- **Ampia scelta di modelli e colori**
- Simple, robust and flexible structure
- Space-saving system
- Wide choice of colors and models



Serranda DOMINUS SFA monolamiera antitempesta verniciata e porta multiuso FREE, per un'azienda leader nella distribuzione di sistemi per serramenti.

DOMINUS SFA rolling shutter single windproof skinned painted and multipurpose doors FREE, for a leading company in the distribution of window systems.

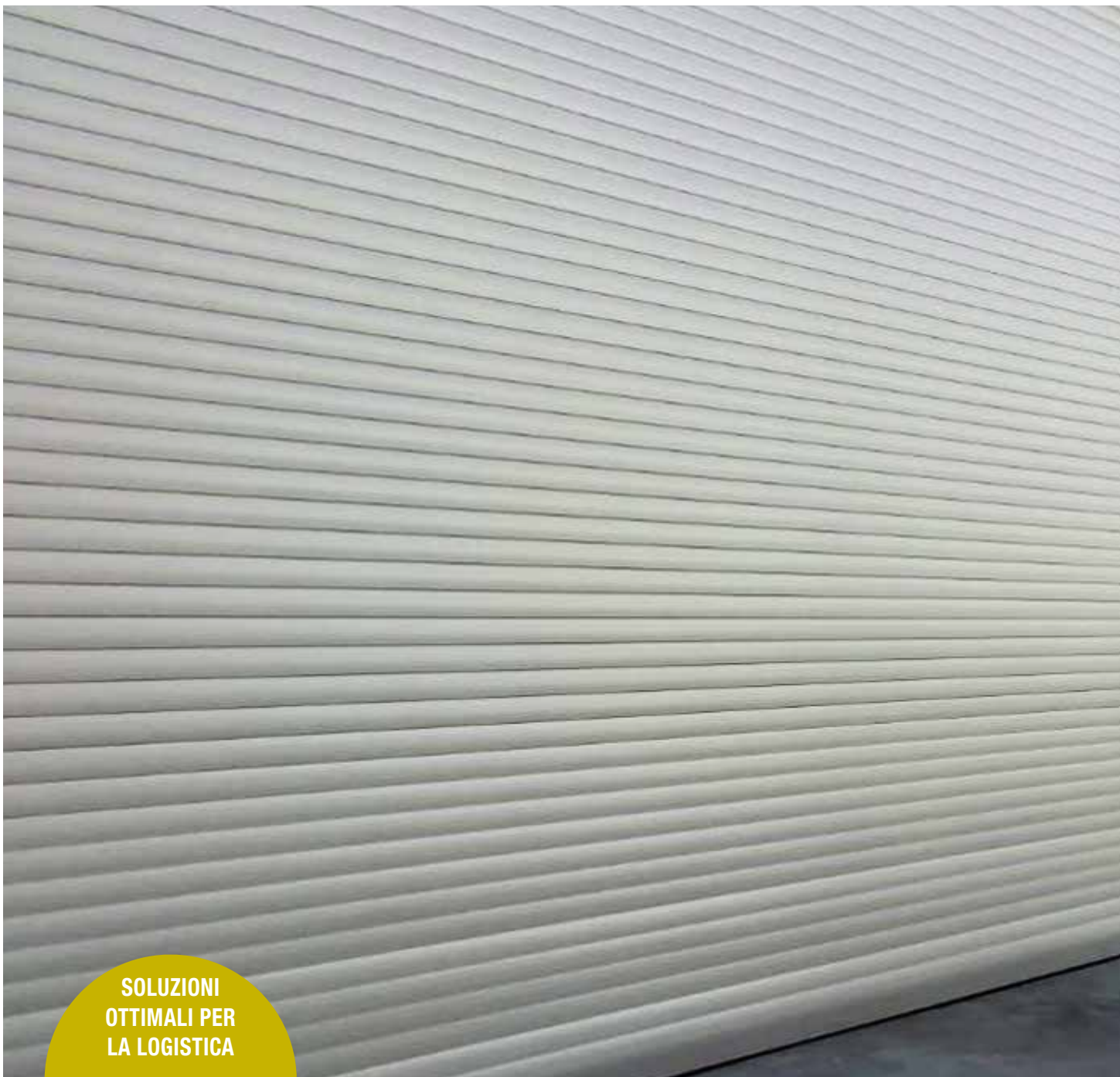

**SOLUZIONI
OTTIMALI PER
LA LOGISTICA**

**OPTIMAL
LOGISTICS
SOLUTIONS**



PRODOTTI CONSIGLIATI:
Quest'azienda idraulica ha scelto le serrande **DOMINUS SFEAC** in acciaio coibentato verniciato a polvere e la serranda **DOMINUS SFAS** con asole sfalsate.

RECOMMENDED PRODUCTS:
This company has chosen insulated steel **DOMINUS SFEAC** rolling shutters painted powder coated and the **DOMINUS SFAS** shutter with irregular slots.

Adattabile ad ogni apertura, perfetta per ogni esigenza, la serranda industriale comporta una estrema facilità di manutenzione grazie alla mancanza di molle, garantendo una maggiore frequenza d'uso. E' possibile realizzare serrande di grandi dimensioni (oltre 15 m di larghezza e 8 m di altezza) studiate e progettate in ogni dettaglio, rispondendo a specifiche richieste di tenuta al vento o isolamento termico.

Adaptable to every opening, perfect for every need, the industrial rolling shutters is extremely easy to maintain thanks to the lack of the springs, thus ensuring a greater frequency of use. We can realize large rolling shutters (over 15 m wide and 8 m high) studied and designed in all details to satisfy specific requirements for wind tightness or thermal insulation.

PROGETTIAMO CON LO SGUARDO RIVOLTO AL FUTURO

WE DESIGN LOOKING TOWARDS THE FUTURE

La Ferraro Group adotta le migliori tecnologie disponibili sul mercato e un comportamento consapevole e responsabile verso gli usi energetici: questo implica un utilizzo più razionale dell'energia, eliminando sprechi dovuti al funzionamento e alla gestione non ottimale di sistemi complessi. Soluzioni a maggior efficienza energetica sono oggetto continuo di ricerca e sviluppo nella nostra azienda per offrire prodotti più performanti.

Ferraro group use the best technologies available and a responsible aware towards the environment: this implies a more rational use of energy, so as eliminating the wastefulness of resources. In our company, the energy efficiency is subjected to a continuous process of research and development project in order to provide high-performance products.



Serranda DOMINUS SFAS asolata sfalsata verniciata colore RAL Grigio 9006 per l'ingresso di una metropolitana.

Irregular perforated DOMINUS SFAS painted RAL Grey 9006 rolling shutter for the entrance to a subway.



Serranda DOMINUS SFDAC in acciaio coibentato verniciato a polvere.

Insulated steel DOMINUS SFDAC rolling shutter painted power coated in San Giorgio del Sannio (BN).

SOLUZIONI PER COMMERCIO, CONDOMINI, VILLE

SOLUTIONS FOR TRADE, CONDOMINIUMS, VILLAS

Le chiusure residenziali LIVING nascono per offrire al cliente soluzioni che rispondano a tre requisiti fondamentali: qualità, eleganza e funzionalità.

La tecnologia e la varietà nella scelta di modelli e finiture consentono di determinare soluzioni personalizzate, nel rispetto della sicurezza.

LIVING residential closures are created to offer customers solutions that meet three basic requirements: quality, elegance and functionality. The technology and the range of models and finishes choice, make them customized solutions, respecting safety.

LIVING RESIDENTIAL DOORS

TIME INDUSTRIAL DOORS

SOLUZIONI PER INDUSTRIA, ENTI E COMUNITÀ

SOLUTIONS FOR INDUSTRY, AUTHORITY AND COMMUNITIES

Le chiusure industriali TIME uniscono affidabilità, robustezza e versatilità: queste caratteristiche vengono saggiamente coniugate con una linea estetica, studiata per ottenere un prodotto di alta qualità. Un mix decisivo per soddisfare tutte le esigenze di attività industriali, enti e comunità.

TIME industrial closures combine reliability, robustness and versatility: these characteristics are added a design studied to obtain a unique and high quality product. A decisive mix to meet all the needs of industrial activities, authority and communities.

LA SERRANDA RESIDENZIALE

RESIDENTIAL ROLLING SHUTTER

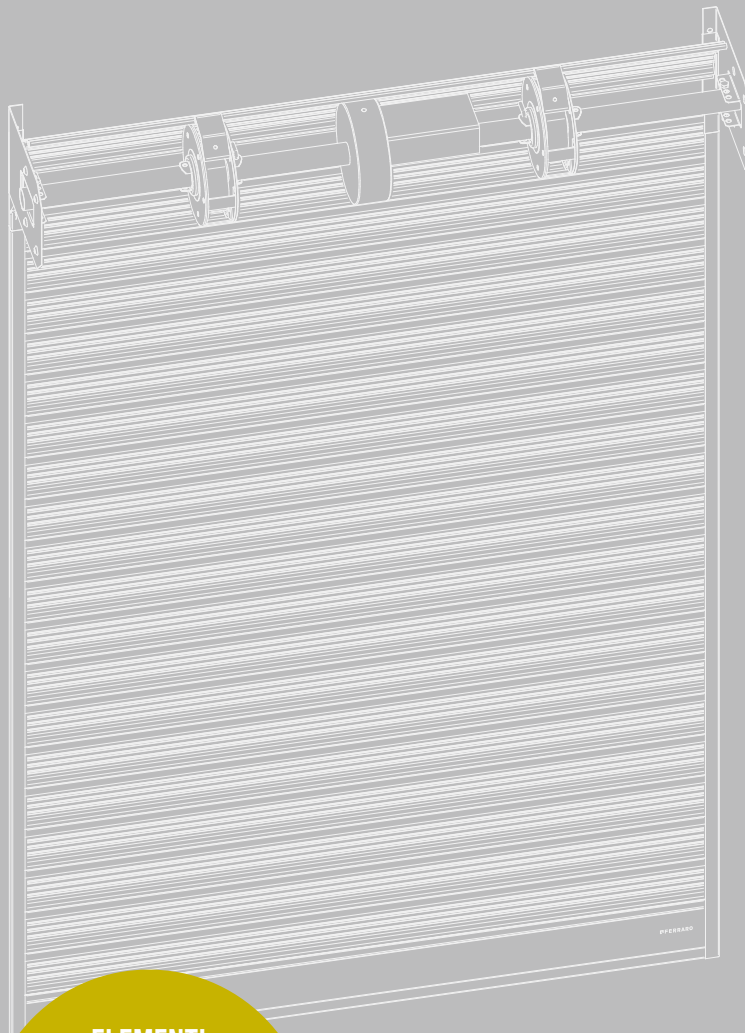

**ELEMENTI
STANDARD O SU
MISURA**

STANDARD OR
CUSTOMIZED
COMPONENTS

ASSE CON SCATOLE PORTAMOLLA E MOTORE COASSIALE

SHAFT WITH SPRING BOXES
AND CENTRAL MOTOR

Albero avvolgitore 48/60/76/101 dimensionato in base al peso e alla larghezza della serranda.
Shaft 48/60/76/101, according to the weight and width of the shutter.

GUIDE DI SCORRIMENTO CON BANDIERE

GUIDES WITH PLATES

Varie tipologie di guide, di vario spessore e sagoma, adattabili a ogni utilizzo.

Various types of guides, various cross section and outline, adaptable to every use.

MANTO

CURTAIN

I vari modelli di serrande rispondono a ogni esigenza e necessità: modelli coibentati con prestazioni di isolamento termico e acustico, oltre a profili monolamiera (ciechi o forati).

The various rolling shutter types are available for every need and desire: insulated model with high performance in thermal and sound isolation, as well as single-skinnes profiles (blind or perforated)

TERMINALE con maniglia e paracolpi di serie.

BOTTOM PROFILE with handle and standard bumper.

Consulta il catalogo online.

Consult the online catalog.

FERRAROPORTE.COM/DOMINUS



FERRARO

ferraroporte.com +39 0825 881321 info@ferraroporte.com

SOLUZIONI
PER GARAGE

GARAGE
SOLUTIONS

LIVING
RESIDENTIAL DOORS

LA SERRANDA RESIDENZIALE: LA SCELTA IDEALE PER CASE, CONDOMINI E VILLE

RESIDENTIAL ROLLING SHUTTERS: THE PERFECT CHOICE FOR HOUSES, APARTMENTS AND VILLAS

Da sempre le serrande avvolgibili sono state utilizzate per la protezione dei locali adibiti ad attività commerciali, depositi o garage: l'impiego di materiali resistenti come la lamiera di acciaio zincato o l'acciaio inox garantiscono la rigidità del manto, e la vasta scelta di modelli (coibentati, forati, antitempesta, ecc) rispondono sia alle esigenze estetiche che di sicurezza, individuando soluzioni personalizzate nel rispetto della sicurezza e della qualità.

Rolling shutters have always been used for the protection of commercial activities, storage or garages: the use of resistant materials such as galvanized steel sheet or stainless steel guarantee the rigidity of the curtain, and the wide choice of models (insulated, perforated, stormproof, etc.) respond both from an aesthetic and safety point of view, identifying customized solutions in respect of safety and quality.

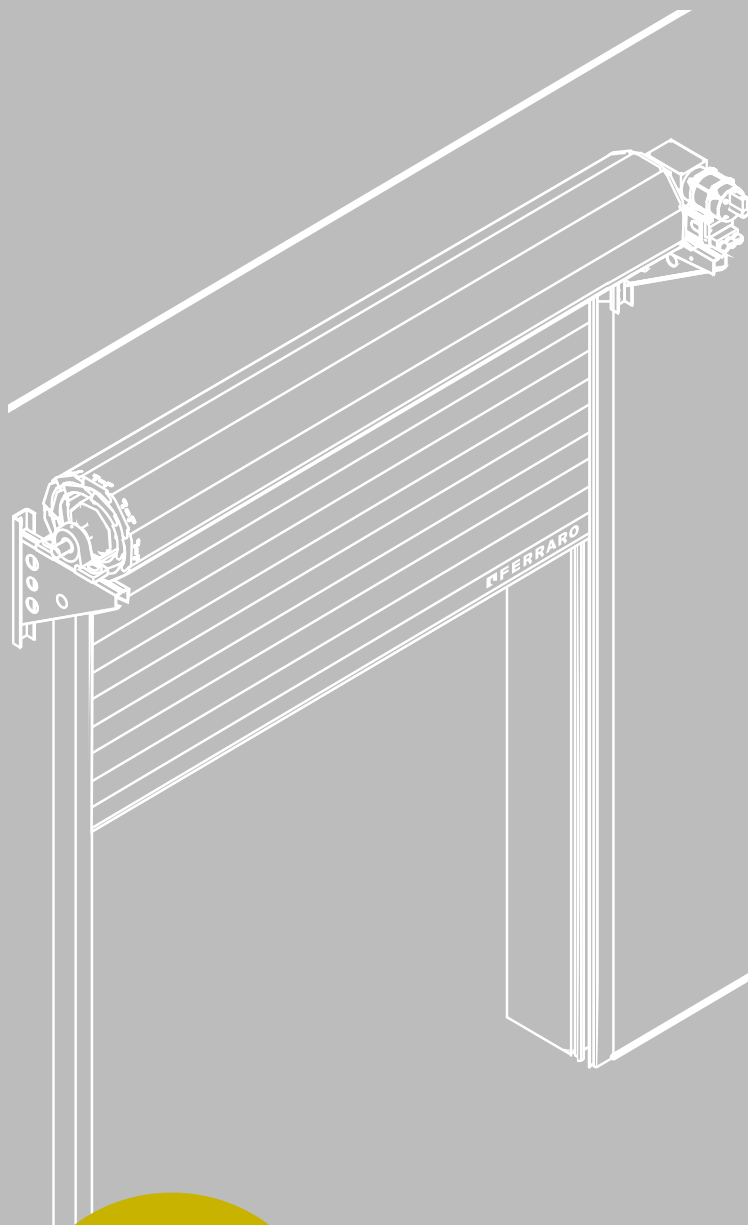

**ELEMENTI
STANDARD O SU
MISURA**

STANDARD OR
CUSTOMIZED
COMPONENTS

LA SERRANDA INDUSTRIALE

INDUSTRIAL ROLLING SHUTTER

**ASSE DI AVVOLGIMENTO CON MOTORE
LATERALE, SENZA SCATOLE PORTAMOLLE**
SHAFT WITH SIDE MOTOR, WITHOUT SPRING BOXES

**Albero avvolgitore dimensionato in base al peso e
alla larghezza della serranda.**

Winder shaft, according to the weight and width of
the shutter.

**GUIDE DI SCORRIMENTO
CON STAFFE DI FISSAGGIO**
GUIDES WITH SUPPORT ONTO THE WALL

**Varie tipologie di guide, di vario spessore e
sagoma, adattabili a ogni utilizzo.**

Various types of guides, various cross section and
outline, adaptable to every use.

MANTO
CURTAIN

**I vari modelli di serrande rispondono a ogni
esigenza e necessità: modelli coibentati con
prestazioni di isolamento termico e acustico, oltre
a profili monolamiera (ciechi o forati).**

The various rolling shutter types are available for
every need and desire: insulated model with high
performance in thermal and sound isolation, as well
as single-skinnes profiles (blind or perforated).

TERMINALE con maniglia e paracolpi di serie.
BOTTOM PROFILE with handle and standard bumper.

Consulta il catalogo online.

Consult the online catalog.

FERRAROPORTE.COM/DOMINUS



GRANDI
DIMENSIONI E USO
INTENSIVO

LARGE SIZES
AND HIGH USE



TIME
INDUSTRIAL DOORS

LA SERRANDA INDUSTRIALE: ADATTA A VARCHI CONDOMINIALI, COMMERCIALI E INDUSTRIALI

INDUSTRIAL ROLLING SHUTTER: SUITABLE FOR APARTMENTS, COMMERCIAL AND INDUSTRIAL GATES

Le serrande industriali rispondono all'esigenza di chiudere varchi di grandi dimensioni: la durabilità nel tempo è estremamente importante, in quanto sono spesso collegate a processi logistici o di produzione nei quali non è ammessa interruzione. I vantaggi sono: nessun impedimento nel vano passaggio, sicurezza e visibilità allo stesso tempo con sistemi microforati o con oblò, praticità di utilizzo grazie ai sistemi di motorizzazione a uso intensivo senza molle di bilanciamento.

Industrial shutters respond to the need to close large gates: durability over time is very important, because shutters are often connected to logistics or production centers where interruption is not allowed. The advantages are: no hindrance in the passageway, safety and visibility at the same time with micro-perforated systems or with windows, ease of use thanks to the motor systems for intensive use without balancing springs.



DOMINUS MONOLAMIERA / SINGLE-SKINNED

Consulta il catalogo online.

Consult the online catalog.

[FERRAROPORTE.COM/DOMINUS](https://www.ferraroporte.com/dominus)



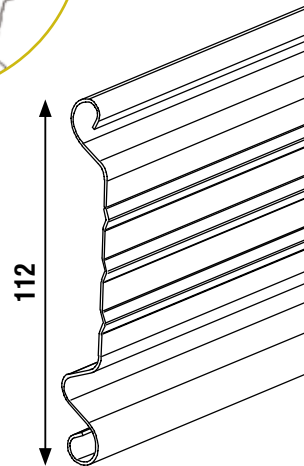

FASCIA MONOLAMIERA
SINGLE-SKINNED STEEL

MODELLO SF

SF MODEL

SOLUZIONE STANDARD PER LE SERRANDE ADATTE A USI COMMERCIALI E RESIDENZIALI. COMPATTA, CON INGOMBRO RIDOTTO PER APERTURE DI MEDIE E GRANDI DIMENSIONI, FUNZIONALE IN TUTTE LE CONDIZIONI.

STANDARD SOLUTION SUITABLE FOR BOTH COMMERCIAL AND RESIDENTIAL USES. IT IS COMPACT, WITH REDUCED DIMENSION FOR OPENING OF MEDIUM AND LARGE DIMENSIONS, FUNCTIONAL IN ALL CONDITIONS.

DISPONIBILE IN 3 SPESSORI E PESI:
3 THICKNESS AND WEIGHTS AVAILABLE:

SF		
8/10	9/10	10/10
10.09 Kg/m ²	11.35 Kg/m ²	12.62 Kg/m ²



ACCESSORI

1. Gancio a L in acciaio zincato (resistente solo a spinta positiva)
2. Gancio a rullo in acciaio zincato (resistente a spinta sia positiva che negativa)
3. Feritoie di aerazione 7x50 mm distanziate a 70 mm
4. Terminale sagomato in acciaio zincato: soluzione standard per serrande industriali (guarnizione a richiesta)
5. Terminale con angolare in acciaio zincato: soluzione standard per serrande residenziali; rinforzato per larghezze superiori a 9000 mm (guarnizione a richiesta)

ACCESSORIES

1. Galvanized L hook (resistant to positive pressures)
2. Galvanized rolling lock (resistant to both positive and negative pressures)
3. Ventilation slots 7x50 mm spaced at 70 mm
4. Galvanized bottom shaped profile: standard for industrial rolling shutters (gasket on request)
5. Galvanized bottom shaped profile with angular: standard for residential rolling shutters; reinforced for widths over 9000 mm (gasket on request)

**MISURA MAX IN
CLASSE AL VENTO 2
12000 X 8000 MM**

MAXIMUM SIZE 12000 X
8000 MM, WINDPROOF
RESISTANCE
CLASS 2



Serranda DOMINUS SF verniciata blu genziana 5010 e giallo navone 1021, per il deposito GLS.
DOMINUS SF rolling shutter painted 5010 Gentian blue and 1021 Colza yellow, for the GLS warehouse.

Il modello SF della linea DOMINUS, è una chiusura estremamente funzionale atta a garantire massima praticità d'uso e sicurezza, essendo la soluzione più tradizionale e conveniente per chiusure civili, commerciali e industriali.

The model DOMINUS SF, is an extremely functional closure designed to guarantee maximum practicality of use and safety. Is the most traditional and convenient solution for civil, commercial and industrial sector.

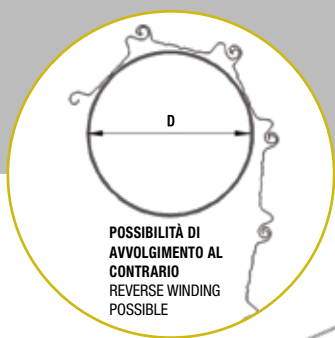

112

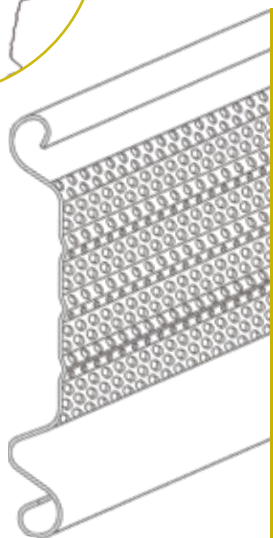

FASCIA MONOLAMIERA MICROFORATA
SINGLE MICROFORATED SKINNED

SFM APPLICAZIONE SF

SF APPLICATION SFM

UNA SOLUZIONE INNOVATIVA PER LE SERRANDE ADIBITE ALLA SICUREZZA DELLE VETRINE DA ESPOSIZIONE È IL PROFILO MICROFORATO. I MICROFORI REALIZZATI SULLA SUPERFICIE DELLA FASCIA CONSENTONO, A INTERNO ILLUMINATO, LA TOTALE VISIONE DELL'AMBIENTE.

AN INNOVATIVE SOLUTION FOR THE PROTECTION OF SHOP WINDOW IS THE MICROFORATED ROLLING SHUTTER. THE HOLES REALIZED ON THE PROFILE OF THE SKINNED ALLOW THE TOTAL VISION OF THE ENVIRONMENT.

DISPONIBILE:
AVAILABLE:

SFM
10/10
10 Kg/m ²

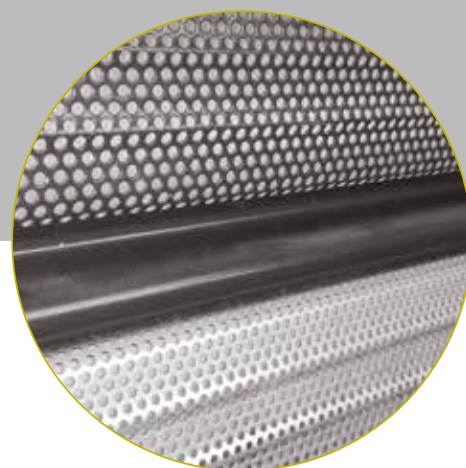
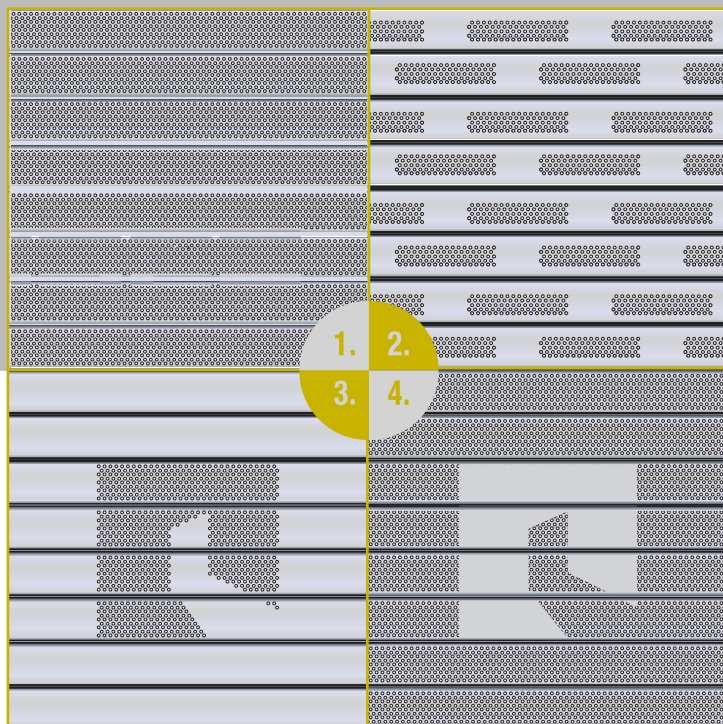

POSSIBILITÀ DI PERSONALIZZAZIONE

POSSIBILITY OF CUSTOMIZATION

1. Traspar
2. Wall
3. Positive logo
4. Negative logo

≈ 30%
AERAZIONE

≈ 30% OF
VENTILATION



Serranda DOMINUS SFM zincata per locali commerciali.
DOMINUS SFM galvanized rolling shutter for commercial activities.

Gli elementi da 10/10 di spessore possono essere forniti con microforatura: in tal modo i profili lasciano passare sufficientemente aria e luce. È perciò un tipo di profilo utilizzato principalmente nelle attività commerciali.

The 10/10 thickness elements can be supplied with microperforation: in this way the profiles allow sufficient air and light to pass through. This finely perforated profile permits the entry of adequate light and air it is mainly used in commercial activities.

SFAR - SFAS

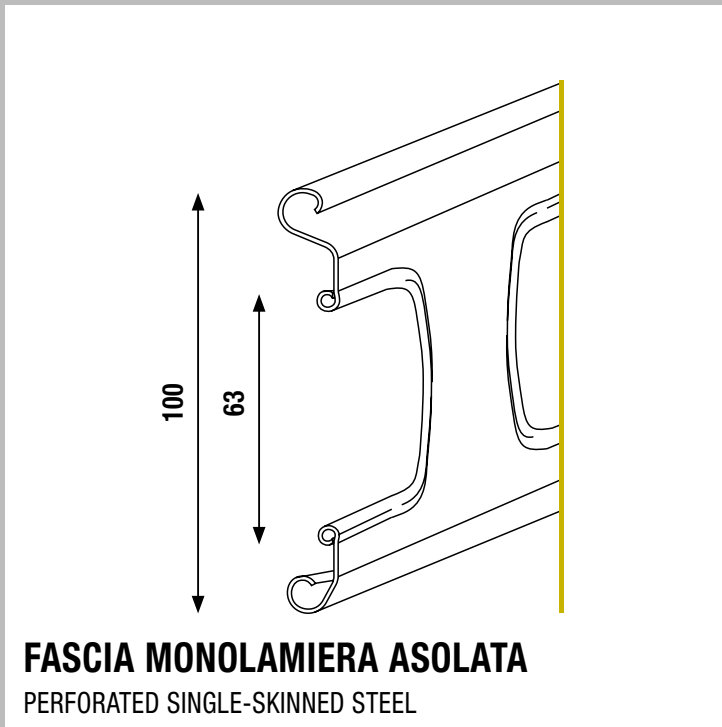

IL PROFILO AD ASOLA, CON I BORDI COMPLETAMENTE ARROTONDATI E ANTITAGLIO È DISPONIBILE IN ACCIAIO ZINCATO (VERNICIATO SU RICHIESTA) O IN ACCIAIO INOX 304/316 SU RICHIESTA.

THIS NEW PROFILE, WITH THE SAFE ROUNDED EDGES IS AVAILABLE GALVANIZED STEEL (PAINTED ON REQUEST) OR STAINLESS STEEL (INOX 304/INOX 316).

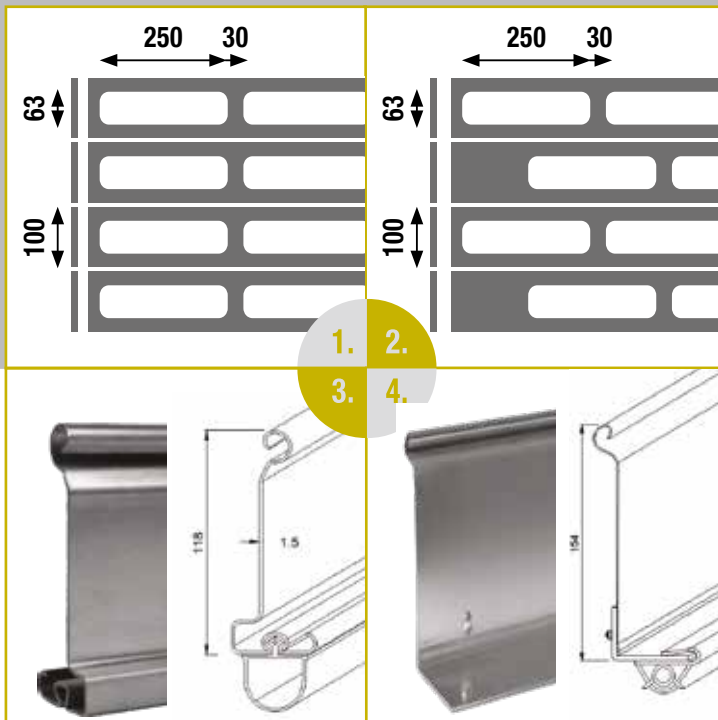

DISPONIBILE IN 2 TIPOLOGIE:
2 TYPES AVAILABLE:

SFAR	SFAS
7,7 Kg/m ²	

COMPONENTI

1. SFAR asola regolare
2. SFAS asola sfalsata
3. Terminale sagomato in acciaio zincato: soluzione standard per serrande industriali (guarnizione a richiesta)
4. Terminale con angolare in acciaio zincato: soluzione standard per serrande residenziali rinforzato per larghezze superiori a 9000 mm (guarnizione a richiesta)

COMPONENTS

1. Regular perforated detail
2. Irregular perforated detail
3. Galvanized bottom shaped profile: standard for industrial ROLLING shutters (gasket on request)
4. Galvanized bottom shaped profile with angular: standard for residential ROLLING shutters; reinforced for widths over 9000 mm (gasket on request)

**MAGGIORE
AERAZIONE**

GREATER AERATION



Serrande DOMINUS SFAS in un complesso condominiale.
DOMINUS SFAS rolling shutters in a condominium complex.

La serranda a maglia robusta, garantisce un prodotto assolutamente innovativo e unico nel suo genere. I bordi arrotondati dell'asola rinforzano in modo notevole il manto della serranda a maglia, esaltando la qualità di finiture ed il gradevole aspetto estetico.

The strenght ROLLING grille shutter guarantee a unique and innovative product. The safe rounded edges give rigidity and strenght to the shutter, exalting the quality of finishes and the pleasant aesthetic appearance.

SFB - SFBR

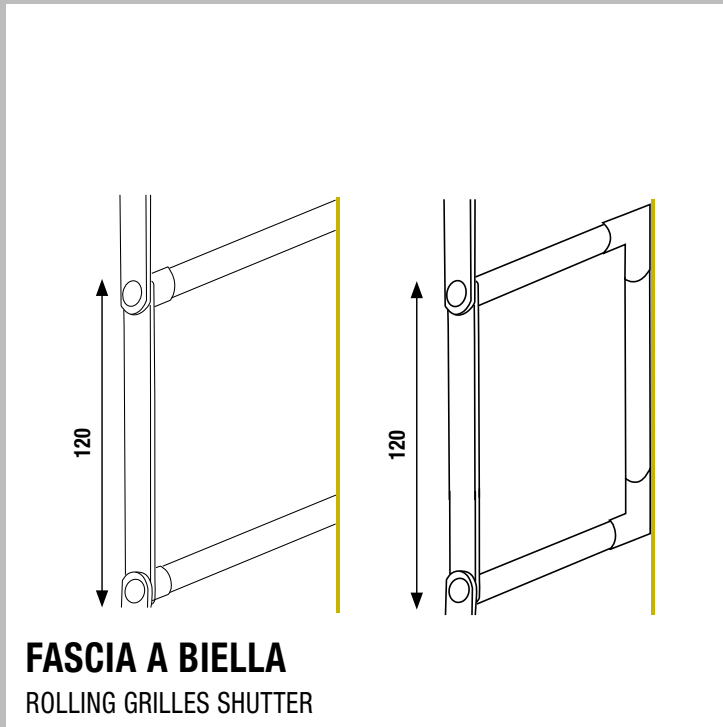

LA SERRANDA SFB È REALIZZATA CON TUBI DI ACCIAIO ZINCATO Ø 18 MM COLLEGATI TRA DI LORO CON BIELLETTE ZINCATATE IN ACCIAIO STAMPATO CON PARTICOLARE NERVATURA A PASSO 400 MM. LA SERRANDA SFBR È RINFORZATA CON DUE BIELLE RAVVICINATE. SI CONSIGLIA LA GUIDA DA ALMENO 40 MM. CATENA LATERALE A RICHIESTA, CONSIGLIATA PER UN MIGLIORE SCORRIMENTO DELLA SERRANDA IN GUIDA.

THE SFB MODEL IS MADE OF GALVANIZED STEEL TUBES Ø 18 MM WITH STEEL JOINTS WITH 180 MM STEP, CONNECTED TO EACH OTHER WITH GALVANIZED STEEL RODES WITH 400 MM STEP. THE SFBR MODEL IS REINFORCED WITH TWO CLOSE RODES. GUIDE RECOMMENDED AT LEAST 40 MM. SIDE CHAIN ON REQUEST, RECOMMENDED FOR BETTER SLIDING OF THE SHUTTER IN GUIDES.

DISPONIBILE IN 2 TIPOLOGIE:

2 TYPES AVAILABLE:

SFB	SFBR
5 Kg/m ²	6 Kg/m ²

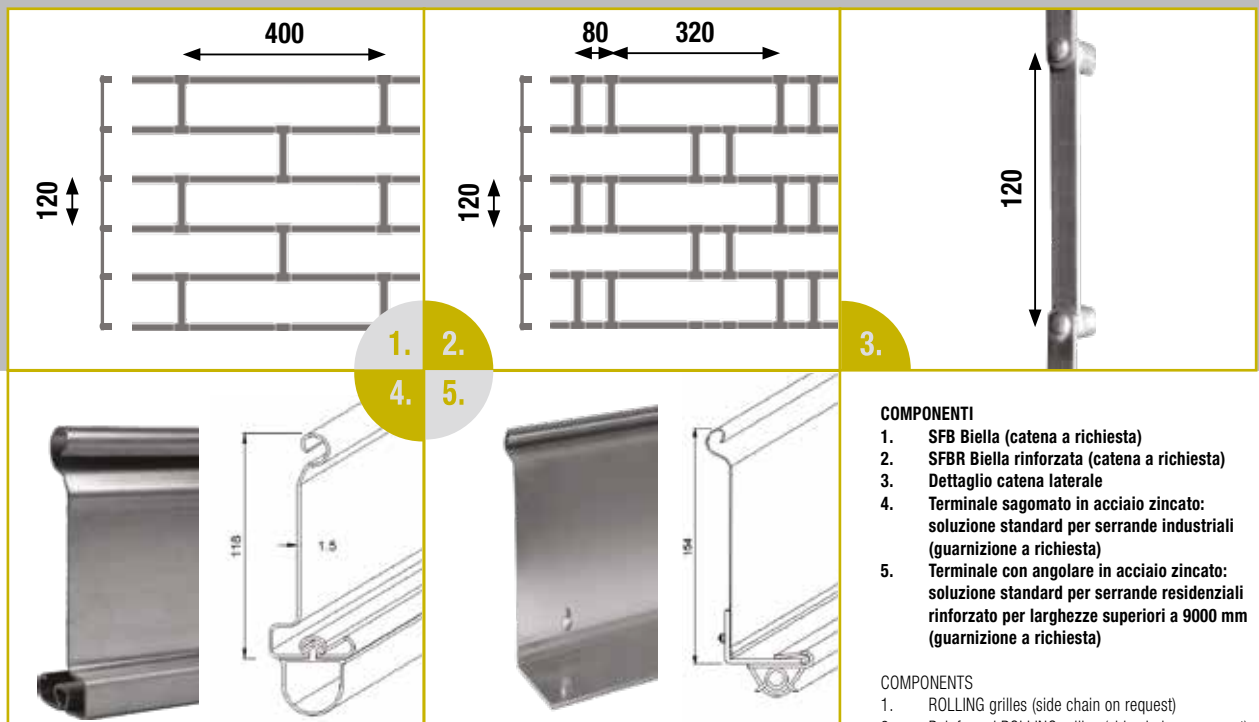

LA CLASSICA
CHIUSURA
COMMERCIALE

CLASSIC
COMMERCIAL
CLOSURE



Serranda DOMINUS SFB a biella zincata per una farmacia.
Galvanized DOMINUS SFB ROLLING grille for a drugstore.

Consigliata a chiusura di esercizi commerciali per i quali sia necessaria la visione completa della merce esposta durante la chiusura, come ad esempio vetrine di negozi o centri commerciali.

Recommended for business exercises's closure, for which the full view of the goods exposed during closing is necessary, come as a showcase for shops or shopping centers.

SFO - SFOR - SFT-SFTR

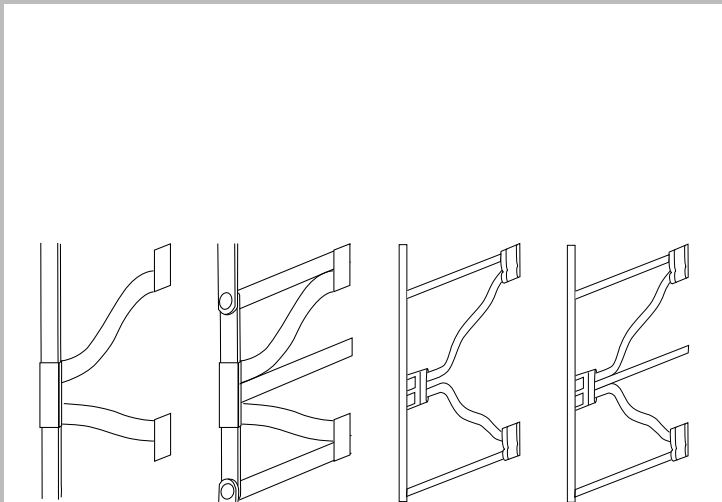

LA SERRANDA SFO È REALIZZATA CON TUBI DI ACCIAIO ZINCATO Ø 14 MM CON SNODI DI ACCIAIO CON PASSO 180 MM, COLLEGATI TRA LORO DA APPOSITI NODI DI ACCIAIO STAMPATO. IL MODELLO SFOR RINFORZATO PREVEDE UN TUBO DI RINFORZO IN ORIZZONTALE.

THE SFO MODEL IS MADE OF GALVANIZED STEEL TUBES Ø 14 MM WITH STEEL JOINTS WITH 180 MM STEP, CONNECTED BETWEEN THEM BY SPECIAL PRINTED STEEL KNOTS. THE SFOR MODEL INCLUDES A HORIZONTAL REINFORCED TUBE.

DISPONIBILE IN 2 TIPOLOGIE:
2 TYPES AVAILABLE:

SFO	SFOR	SFT	SFTR
10 Kg/m ²	14 Kg/m ²	11,6 Kg/m ²	17,3/m ²

ONDA - ONDA RINFORZATA - TONDO PIENO

MESH - REINFORCED MESH - FULL ROUND

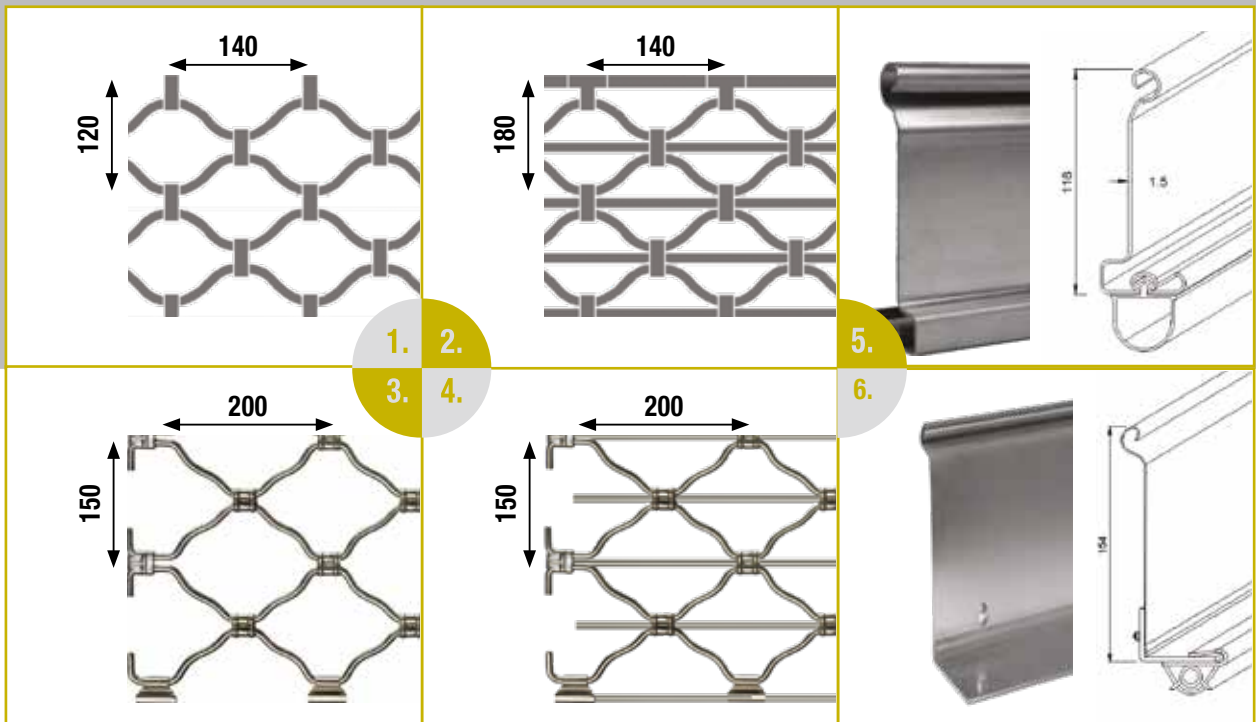

INTELAIATURA ROBUSTA

STURDY FRAME



DOMINUS SFO per la vetrina di un centro ottico.
DOMINUS SFO for the shop window of an optical center.

Le serrande a onda sono i tipi di chiusura maggiormente utilizzati per la sicurezza delle vetrine da esposizione; il loro disegno armonizza particolarmente i locali commerciali dei centri storici.

This shutters are the types of closing most used vision shutters; its design is particularly armonized by the commercial premises of historical centers

COMPONENTI

1. SFO onda
2. SFOR onda rinforzata
3. SFT tondo pieno
4. SFTR tondo pieno rinforzato
5. Terminale sagomato in acciaio zincato: soluzione standard per serrande industriali (guarnizione a richiesta)
6. Terminale con angolare in acciaio zincato: soluzione standard per serrande residenziali rinforzato per larghezze superiori a 9000 mm (guarnizione a richiesta)

COMPONENTS

1. SFO mesh detail
2. SFOR reinforced mesh detail
3. SFT full round detail
4. SFT reinforced full round detail
5. Galvanized bottom shaped profile: standard for industrial ROLLING shutters (gasket on request)
6. Galvanized bottom shaped profile with angular: standard for residential ROLLING shutters; rinforced for widths over 9000 mm (gasket on request)



DOMINUS SERR. SFLUX / SFLUX ROLLING SHUTTER

Consulta il catalogo online.

Consult the online catalog.

FERRAROPORTE.COM/DOMINUS



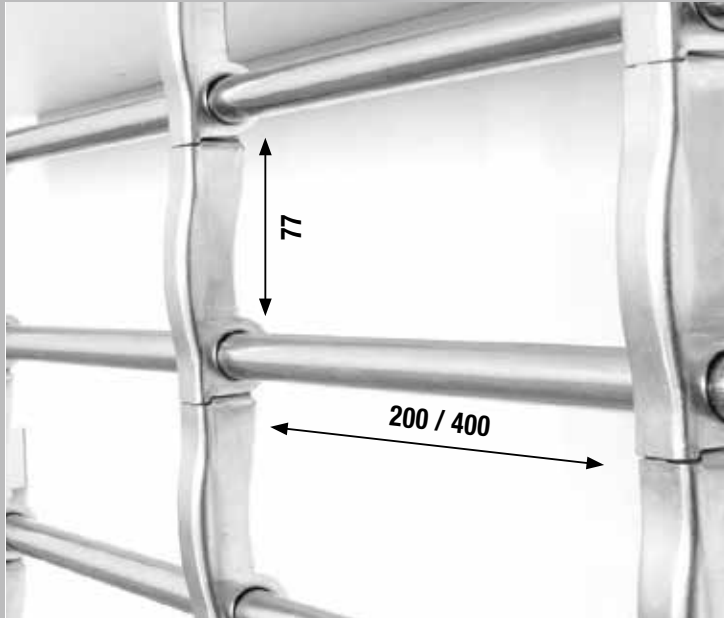

FASCIA TRASPARENTE A BIELLA LINEARE
TRANSPARENT ROLLING GRILLES SHUTTER

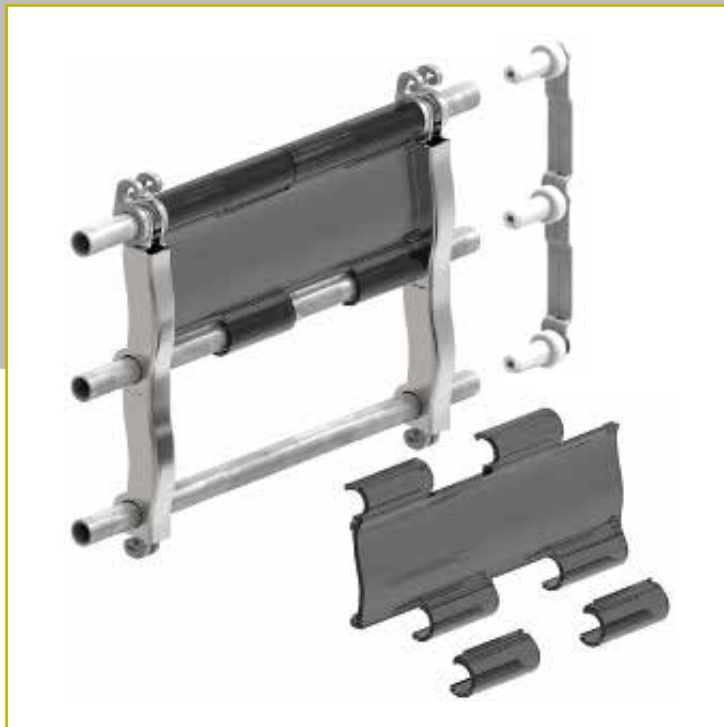

SERRANDA SFLUX

SFLUX ROLLING SHUTTER

IL MANTO DELLA SFLUX È REALIZZATO CON TUBI IN ACCIAIO ZINCATO DI DIAMETRO 14 MM (A RICHIESTA IN ACCIAIO INOX), COLLEGATI DA BIELLETTE LINEARI (NON SFALSATE), POSIZIONATE CON INTERASSE 400 MM (SFLUX/40) O 200 MM (SFLUX/20). NELLA PARTE INFERIORE È SEMPRE FORNITA UNA FASCIA CIECA (SF) E IL FASCIONE TERMINALE A PAVIMENTO COMPLETO DI ANGOLARE PER IL FISSAGGIO DELLA SERRANDA. È DISPONIBILE IN ACCIAIO ZINCATO E IN ACCIAIO INOX SU RICHIESTA.

THE SFLUX CURTAIN IS MADE OF GALVANIZED STEEL TUBES OF 14 MM DIAMETER (ON REQUEST IN STAINLESS STEEL), CONNECTED BY LINEAR LINK (NOT CRUSHED), PLACED WITH INTERAXIS 400 MM (SFLUX / 40) OR 200 MM (SFLUX / 20). IN THE LOWER PART IT IS ALWAYS PROVIDED A BLIND BAND (SF) AND A BOTTOM PROFILE WITH ANGULAR FOR FIXING. IT IS AVAILABLE IN GALVANIZED STEEL AND STAINLESS STEEL ON REQUEST.

DISPONIBILE IN 2 TIPOLOGIE:

2 TYPES AVAILABLE:

SFLUX/40	SFLUX/20
7,5 kg/m ²	9 kg/m ²

APPLICAZIONI

- Tubo e Bielletta in acciaio zincato (a richiesta acciaio inox)
- Finestra in policarbonato
- Catena laterale da utilizzare con guida C50 pressopiegata

APPLICAZIONI

- Galvanized steel tube and vertical link (stainless steel on request)
- Polycarbonate cap
- Side chain using with C50 guide

TRASPARENZA,
ARIA ED ESTETICA

TRANSPARENCY,
AIR AND
AESTHETICS



DOMINUS SFLUX per una gioielleria.
DOMINUS SFLUX for a jewelry store.

LA FORZA DELL'ACCIAIO E L'ELEGANZA DEL POLICARBONATO

THE STRENGTH OF THE STEEL AND THE ELEGANCE OF POLYCARBONATE

La serranda SFLUX si caratterizza per una nuova estetica elegante e moderna: si presta a varie personalizzazioni e ad utilizzazioni che spaziano dalle chiusure di porticati a vetrine in ambienti commerciali, tramite l'utilizzo di finestre in policarbonato.

The SFLUX model is characterized by a new elegant and modern aesthetics: lends itself to various customizations and uses that range from closures of arcades to shop windows in commercial environments, through the use of polycarbonate windows.



A RICHIESTA
ACCIAIO INOX

STAINLESS STEEL
ON REQUEST

DOMINUS SFLUX per le vetrine di esercizi commerciali.
DOMINUS SFLUX for shop windows.



Una serranda dal design unico, fondamentale per le attività commerciali che desiderano farsi notare: ideale per contesti di pregio.

A rolling shutter with a unique design, essential for the commercial activities that must be noticed: ideal for prestigious contexts.

SERRANDA SF LIGHT

APPLICAZIONI

1. Fasce in policarbonato trasparente con protezione UV collegate da profili in alluminio estruso
2. Fasce di attacco al rullo modello SF zincato
3. Terminale con angolare in acciaio zincato (guarnizione a richiesta)



FASCIA IN POLICARBONATO TRASPARENTE

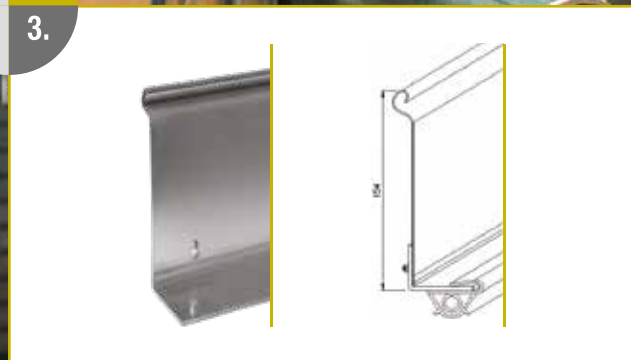

1.
2.
3.





DOMINUS MOD. ANTITEMPESTA / WINDPROOF MOD.

Consulta il catalogo online.

Consult the online catalog.

FERRAROPORTE.COM/DOMINUS



MODELLO SFA

SFA MODEL

STRUTTURA ROBUSTA, PARTICOLARMENTE ADATTA ALL'INDUSTRIA E AL COMMERCIO. IL PROFILO BOMBATO CONFERISCE MIGLIORE RESISTENZA E MAGGIORE SICUREZZA.

STURDY STRUCTURE, SUITABLE FOR INDUSTRY AND TRADE SECTOR. THE ROUNDED PROFILE PROVIDES BETTER RESISTANCE AND SAFETY.

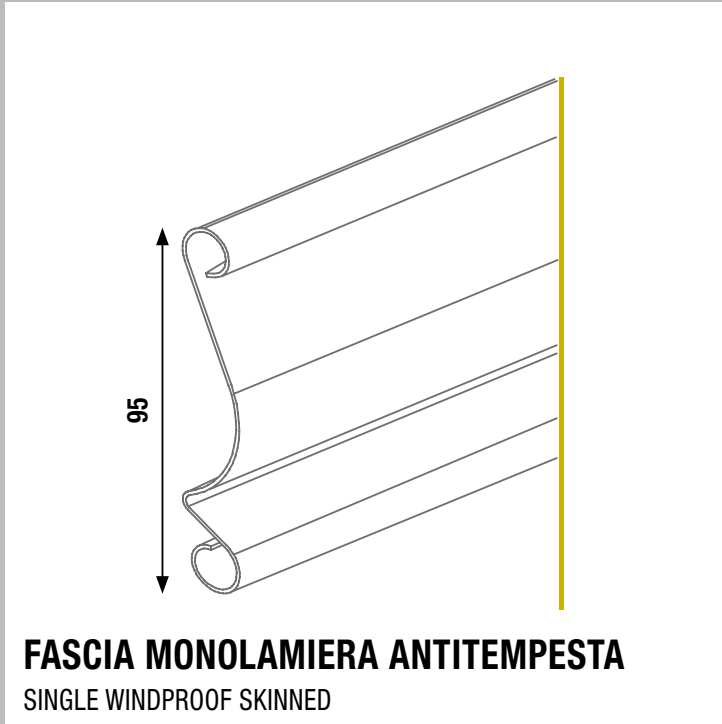

DISPONIBILE IN 2 SPESSORI E PESI:

2 THICKNESS AND WEIGHTS AVAILABLE:

9/10	10/10
13,38 Kg/m ²	15 Kg/m ²

ACCESSORI

1. Gancio a L in acciaio zincato (resistente solo a spinta positiva)
2. Gancio a rullo in acciaio zincato (resistente a spinta sia positiva che negativa)
3. Terminale sagomato in acciaio zincato: soluzione standard per serrande industriali (guarnizione a richiesta)
4. Terminale con angolare in acciaio zincato: soluzione standard per serrande residenziali; rinforzato per larghezze superiori a 9000 mm (guarnizione a richiesta)

ACCESSORI

1. Galvanized L hook (resistant to positive pressures)
2. Galvanized rolling lock (resistant to both positive and negative pressures)
3. Galvanized bottom shaped profile: standard for industrial ROLLING shutters (gasket on request)
4. Galvanized bottom shaped profile with angular: standard for residential ROLLING shutters; reinforced for widths over 9000 mm (gasket on request)

FERRARO

ferraroporte.com +39 0825 881321 info@ferraroporte.com

**TENUTA
ANTITEMPESTA
E DURABILITÀ
NEL TEMPO**

WINDPROOF
RESISTANCE
AND DURABILITY



Serranda DOMINUS SFA zincata per industria metallurgica.
Galvanized DOMINUS SFA for metal industry.

Il profilo delle serrande antitempesta è sagomato e rinforzato: ciò contribuisce a dare particolare rigidità alla serranda nel suo complesso e assicurare resistenza antieffrazione.

The profile of the windproof rolling shutters is shaped and reinforced: this helps to give rigidity to the rolling shutter and ensures anti-burglary resistance.

MODELLO SFMA

SFMA MODEL

UNA SOLUZIONE INNOVATIVA PER LE SERRANDE ADIBITE ALLA SICUREZZA DELLE VETRINE DA ESPOSIZIONE È IL PROFILO MICROFORATO. I MICROFORI REALIZZATI SULLA SUPERFICIE DELLA FASCIA CONSENTONO, A INTERNO ILLUMINATO, LA TOTALE VISIONE DELL'AMBIENTE.

AN INNOVATIVE SOLUTION FOR THE PROTECTION OF SHOP WINDOW IS THE MICROFORATED ROLLING SHUTTER. THE HOLES REALIZED ON THE PROFILE OF THE SKINNED ALLOW THE TOTAL VISION OF THE ENVIRONMENT.

DISPONIBILE:

AVAILABLE:

SFMA
10/10
12 Kg/m ²

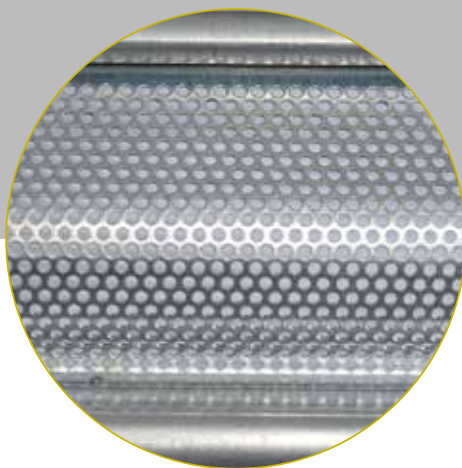
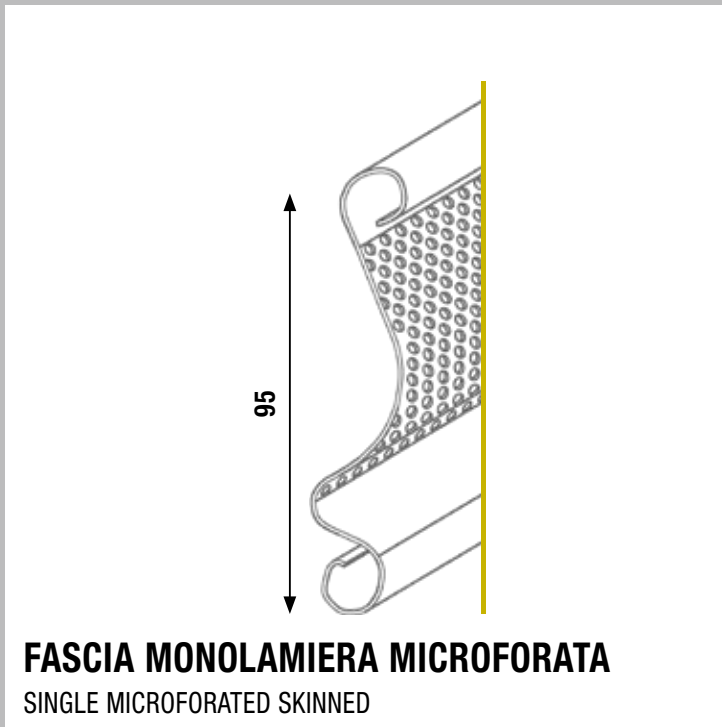

≈ 30%
AERAZIONE

≈ 30% OF
VENTILATION



Serranda DOMINUS SFMA zincata per locali commerciali.
DOMINUS SFMA galvanized rolling shutter for commercial activities.

Gli elementi da 10/10 di spessore possono essere forniti con microforatura: in tal modo i profili lasciano passare sufficientemente aria e luce. È perciò un tipo di profilo utilizzato principalmente nelle attività commerciali.

The 10/10 thickness elements can be supplied with microperforation: in this way the profiles allow sufficient air and light to pass through. This finely perforated profile permits the entry of adequate light and air it is mainly used in commercial activities.

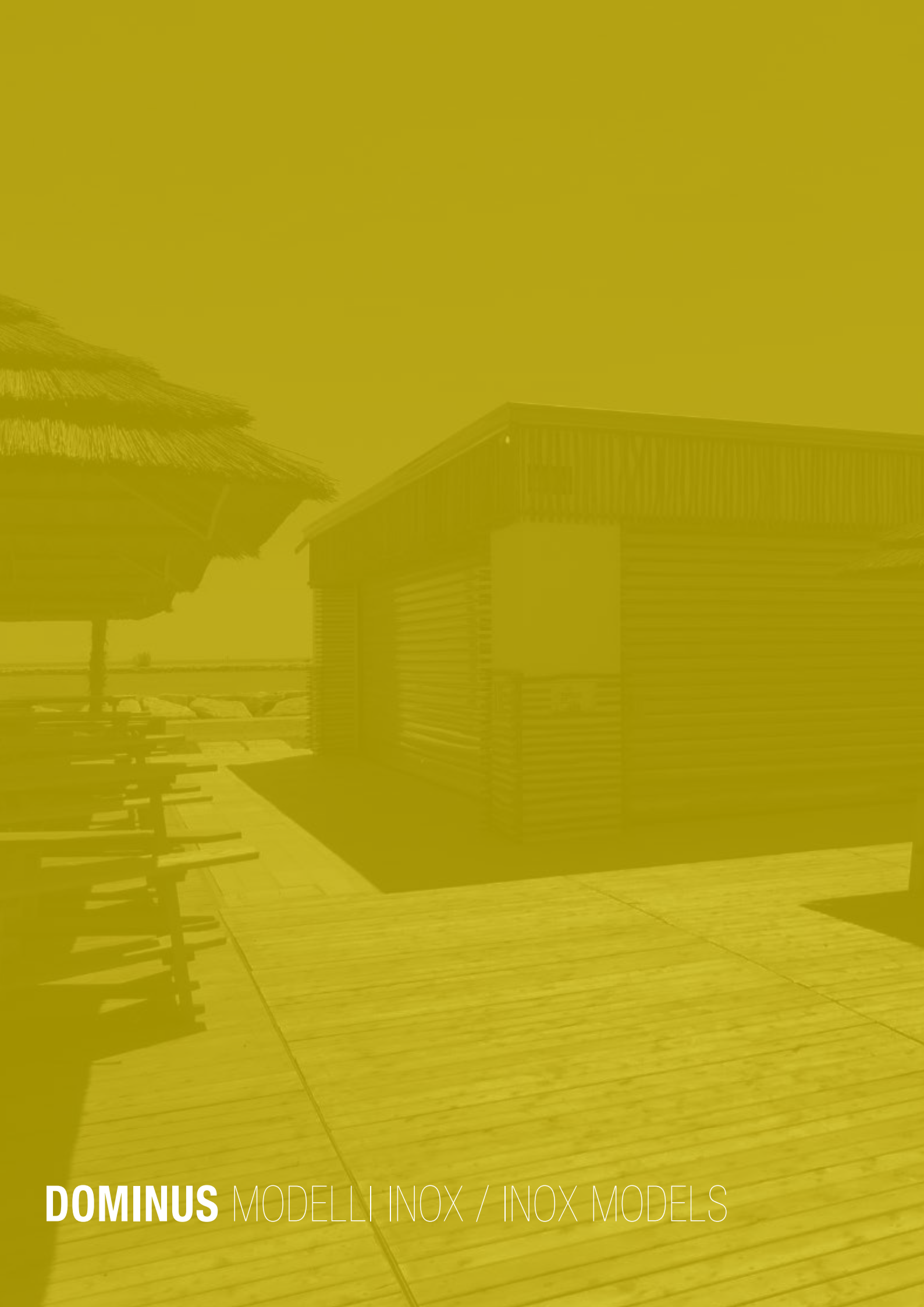

DOMINUS MODELLI INOX / INOX MODELS

Consulta il catalogo online.

Consult the online catalog.

FERRAROPORTE.COM/DOMINUS



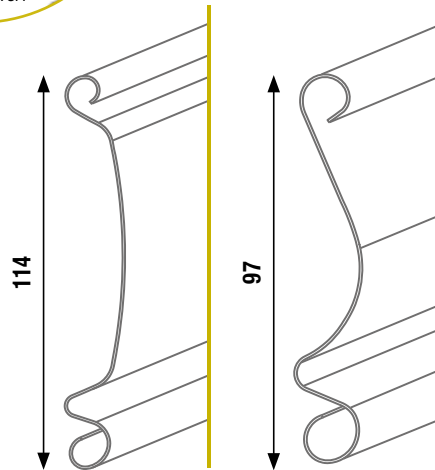
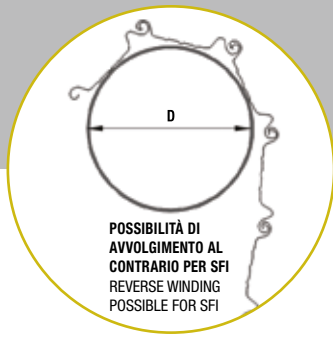

FASCE ACCIAIO INOX AISI 316
SINGLE STAINLESS STEEL AISI 316 SKINNED

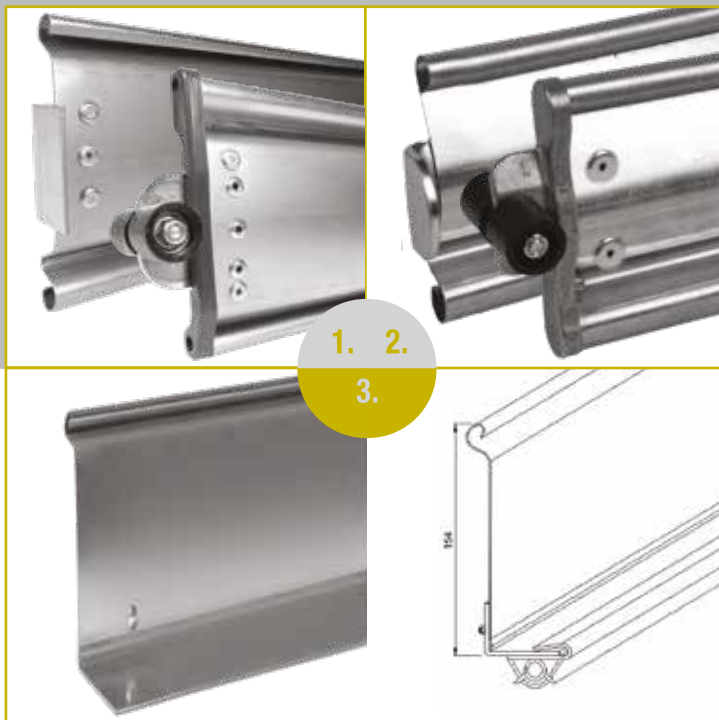

MODELLI SFI / SFAI

SFI / SFAI MODELS

LE SERRANDE IN ACCIAIO INOX HANNO UNA NOTEVOLE RESISTENZA ALLA CORROSIONE, ASSICURANDO UNA INALTERABILITÀ CHE CONSENTE DI MANTENERE BELLEZZA E FUNZIONALITÀ NEL TEMPO.

STAINLESS STEEL ROLLING SHUTTERS HAVE REMARKABLE RESISTANCE TO CORROSION. THIS PRODUCT ALLOWS TO KEEP BEAUTY AND FUNCTIONALITY IN TIME.

DISPONIBILE IN 2 PESI:

2 WEIGHTS AVAILABLE:

SFI	SFAI
8/10	
9,93 Kg/m ²	11,67 Kg/m ²

ACCESSORI

1. Gancio a L in acciaio inox o a rullo SFI
2. Gancio a L in acciaio inox o a rullo SFAI
3. Terminale con angolare in acciaio inox AISI 316 Scotch Brite. Rinforzato per larghezze superiori a 9000 mm. Guarnizione a richiesta.

ACCESSORIES

1. Stainless steel L Hook or rolling lock SFI
2. Stainless steel L Hook or rolling lock SFAI
3. Bottom profile with AISI 316 Scotch Brite stainless steel corner. Rinfoced for widths over 9000 mm. Gasket on request.

**AISI 316
Scotch Brite**

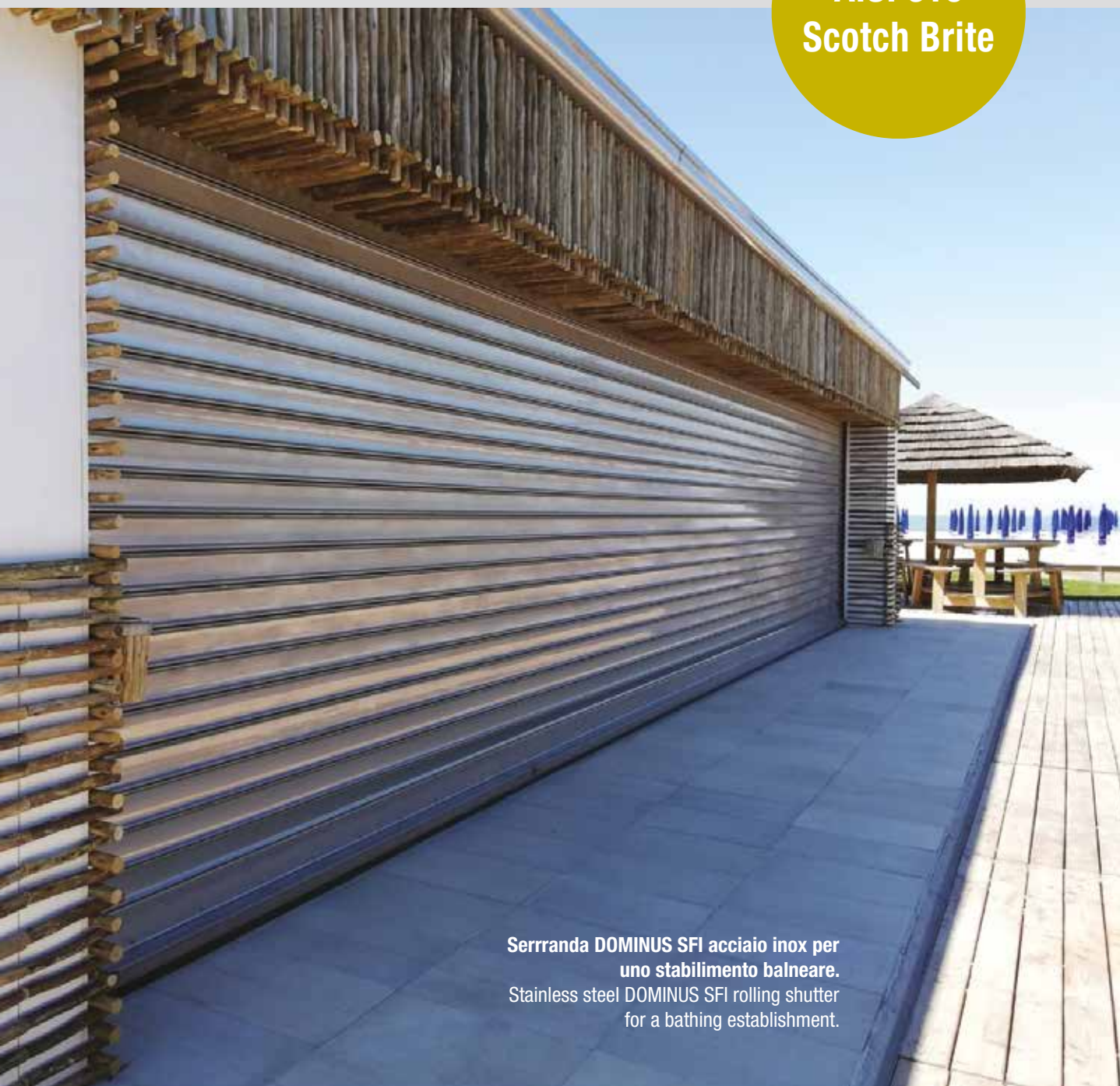

**Serranda DOMINUS SFI acciaio inox per
uno stabilimento balneare.**
Stainless steel DOMINUS SFI rolling shutter
for a bathing establishment.

Le serrande in acciaio inox, per le caratteristiche del materiale utilizzato, sono consigliate per ambienti aggressivi, ovvero zone marine, luoghi con particolari condizioni atmosferiche aggressive o ossidanti, industrie alimentari.

The Rolling Shutters in stainless steel, due to the characteristics of the material used, are recommended for aggressive environments. Sea areas or places with aggressive or oxidizing environments such as food industries.



DOMINUS IMPACCHETTABILE / PACKABLE

Consulta il catalogo online.

Consult the online catalog.

FERRAROPORTE.COM/DOMINUS



SERRANDA IMPACCHETTABILE ORIZZONTALE

HORIZONTAL PACKABLE SHUTTER

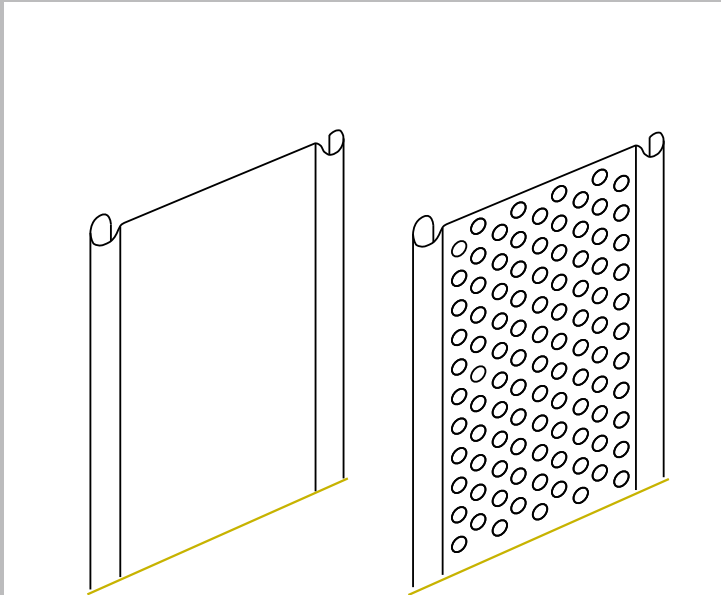

FASCIA IMPACCHETTAMENTO ORIZZONTALE

SINGLE-SKINNED ORIZONTAL PACKABLE

LA NUOVA CHIUSURA IMPACCHETTABILE A SCORRIMENTO ORIZZONTALE E' IDEALE PER SEPARARE AMPI SPAZI, PROTEGGENDOLI CON UN SISTEMA DI DIVISIONE SICURO E DI FACILE MANOVRA. IL SUO UTILIZZO È INDICATO PER GALLERIE COMMERCIALI, AEROPORTI, FIERE, SCUOLE, BANCHI RECEPTION, ED OGNI ACCESSO SIA INTERNO CHE ESTERNO.

CARATTERISTICHE PRINCIPALI:

- Larghezza illimitata
- Posa semplificata e non invasiva
- Ingombri ridotti
- Minimo ingombro della guida portante superiore (39 x 39 mm)
- Ridotto ingombro dell'impacchettamento laterale
- Assenza di guida inferiore a pavimento
- Scorrimento lineare o curvilineo

IT IS THE NEW HORIZONTAL SLIDING FOLDING CLOSURE IDEAL TO SEPARATE LARGE AREAS AND TO PROTECT THEM USING A SAFETY AND EASY USE DIVIDING SYSTEM. ITS USE IS ADVISED FOR MALL GALLERIES, AIRPORTS, EXHIBITIONS, RECEPTION AND ALL INTERNAL OR EXTERNAL ACCESSES.

MORE RELEVANT CHARACTERISTICS:

- Illimitate width
- Very easy installation and minimally invasive
- Reduced encumbrances
- Minimum size of top-hung track (39 x 39 mm)
- Reduced encumbrance of side stack
- No lower track on the floor.
- Linear or curvilinear sliding

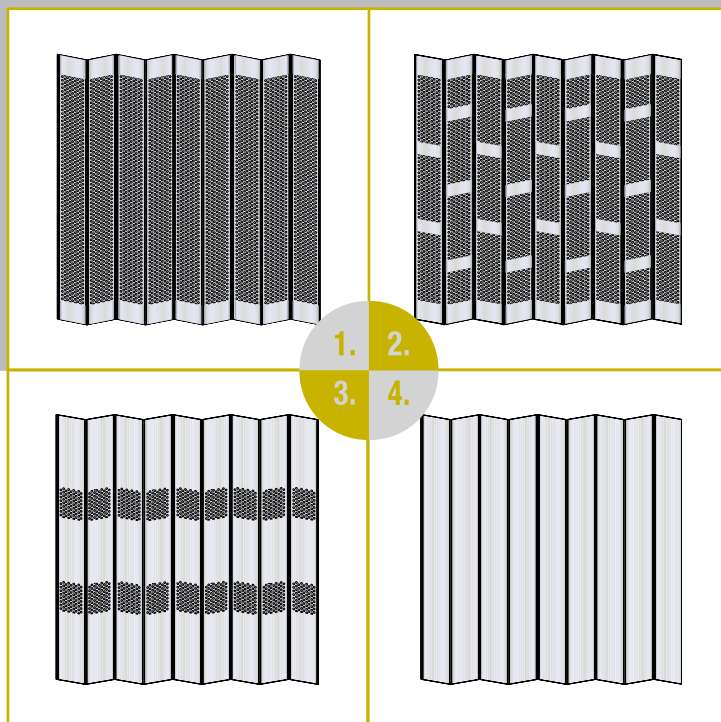

POSSIBILITÀ DI PERSONALIZZAZIONE

POSSIBILITY OF CUSTOMIZATION

1. Standard
2. Wall
3. Personalizzata
4. Elementi chiechi

LARGHEZZA
SENZA LIMITI

WIDTH
LIMITLESS

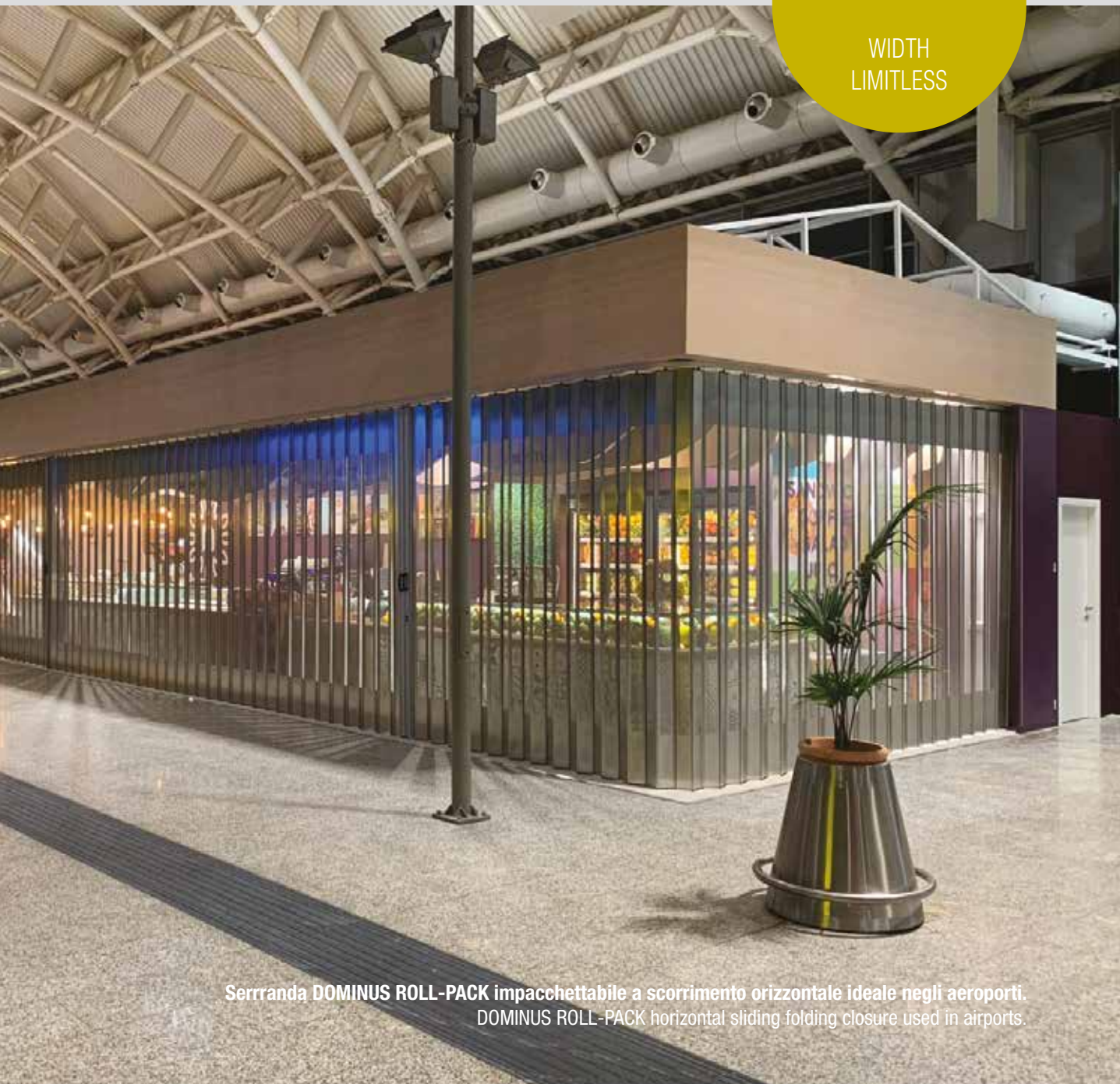

Serranda DOMINUS ROLL-PACK impacchettabile a scorrimento orizzontale ideale negli aeroporti.
DOMINUS ROLL-PACK horizontal sliding folding closure used in airports.

L'assenza di guida inferiore lascia il pavimento completamente libero da ingombri. La modularità di costruzione permette di realizzare anche grandi larghezze senza problematiche di installazione e di trasporto. Lo scorrimento laterale è possibile con una semplice spinta manuale grazie a carrelli con cuscinetti a sfere inseriti nella guida portante superiore. La manovra è fluida e silenziosa.

The absence of lower track leaves the floor completely free from encumbrances. The modular construction allows to realize also large widths without installation problems and transport. The side-sliding is possible with simple manual push through wheels with ball bearings inserted in the top-hung track. The manual operation is flowing and noiseless.



Guida superiore
Top-hung track



Serratura centrale
Central lock



Chiavistello con catenaccio
Latch with locking pin

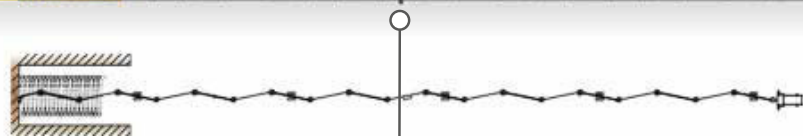
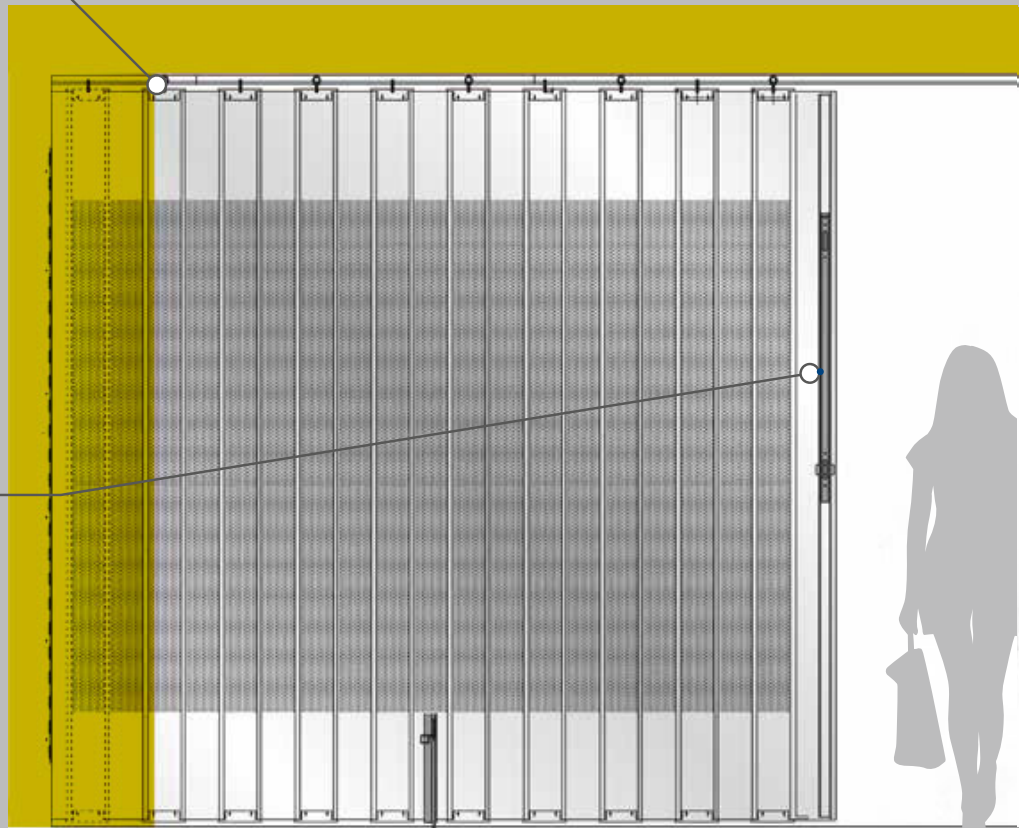
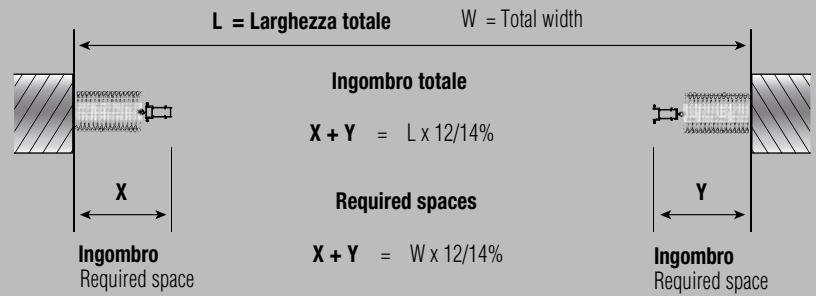

Occhio a pavimento in acciaio inox con protezione a molla antipolvere

Stainless steel floor socket contains a dust cap that protects the spring mechanism underneath

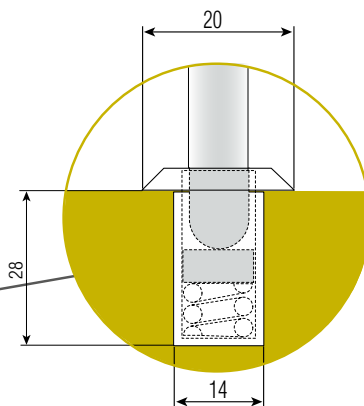

Giunzione guida / Guide junction

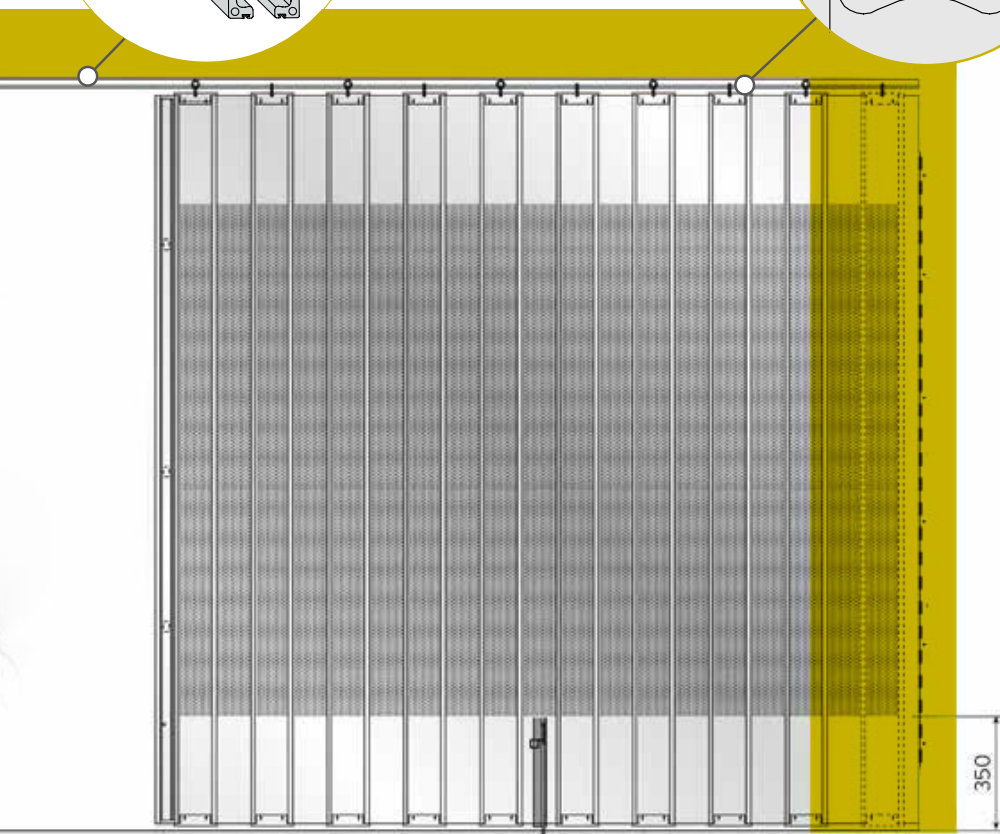
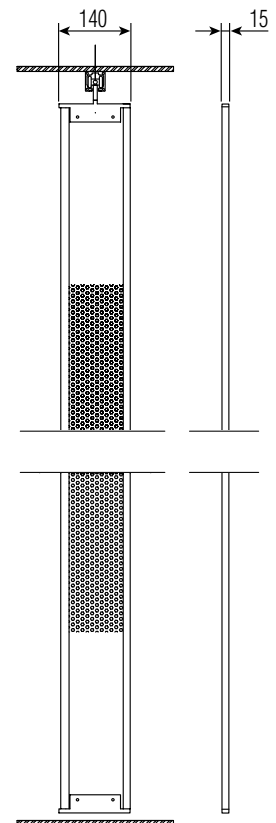
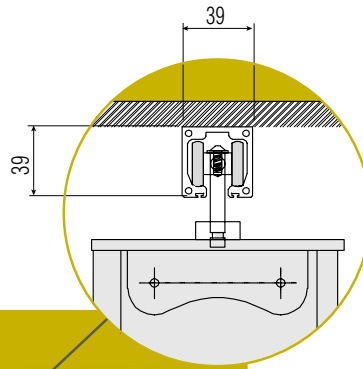
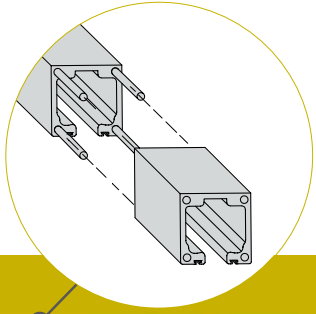

Profili in alluminio estruso permettono l'alloggiamento delle serrature e consentono la precisa e sicura controbattuta

Extruded aluminum profiles allow the insertion of locks and allow precise and safe counter-locking

Dimensione canale di scorrimento

Sliding channel dimension

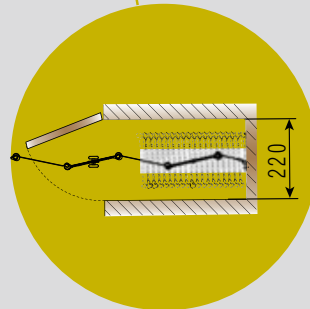

ESEMPI DI POSSIBILI APPLICAZIONI ROLL-PACK

ROLL-PACK SAMPLE LAYOUTS

Impacco doppio a vista

Bi-parting straight arrangement with visible stacks

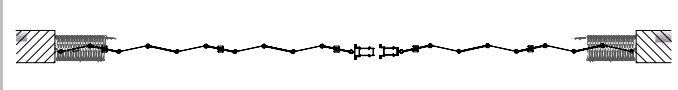

Impacco singolo a scomparsa

Stacking to one side with stack in custom build box

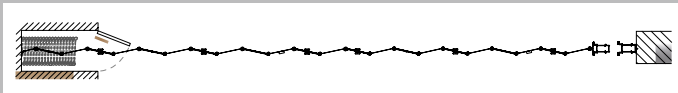

Impacco doppio a scomparsa

Bi-parting with stacks in custom build boxes

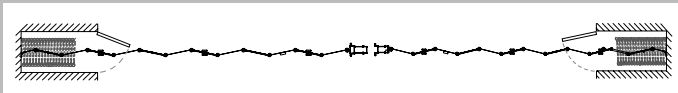

ROLL-PACK È REALIZZABILE CON SCORRIMENTO DRITTO OPPURE IN CURVA, PERMETTE DI ESEGUIRE IN SUCESSIONE CURVE DI DIVERSO RAGGIO. PER L'ALLOGGIAMENTO DELLA RACCOLTA, È POSSIBILE REALIZZARE UNO CASSONETTO CON UN SPORTELLO INTEGRATO ALL'AMBIENTAZIONE.

ROLL-PACK FIT VIRTUALLY ANY CURVED AND THUS ALLOW ENDLESS CREATIVITY. MORE COMPLICATED LAYOUTS CAN BE ACHIEVED USING A SPECIAL RADIUS CURVE. TO CLOSE THE STACKING IT IS POSSIBLE TO MAKE A BOX WITH A DOOR INTEGRATED INTO THE SETTING.

IMPACCHETTAMENTO
LINEARE
A INGOMBRO RIDOTTO

LINEAR PACKABLE
WITH MINIMUM SIZE

**CURVE E
RACCORDI**

**CURVES AND
JUNCTIONS**

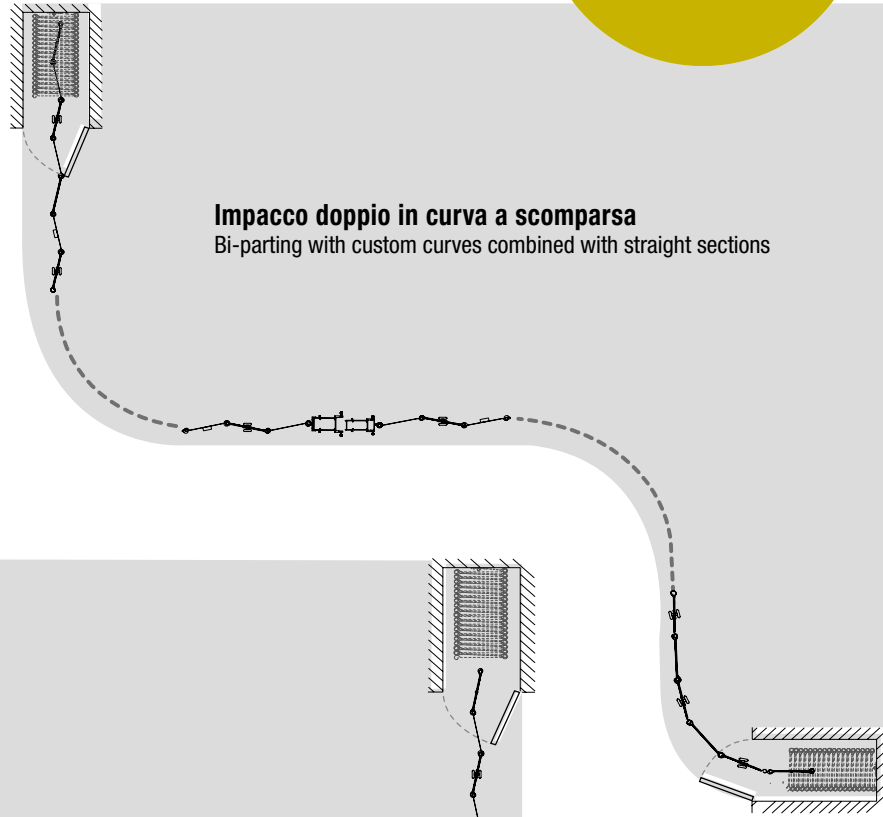

Impacco doppio in curva a scomparsa

Bi-parting with custom curves combined with straight sections

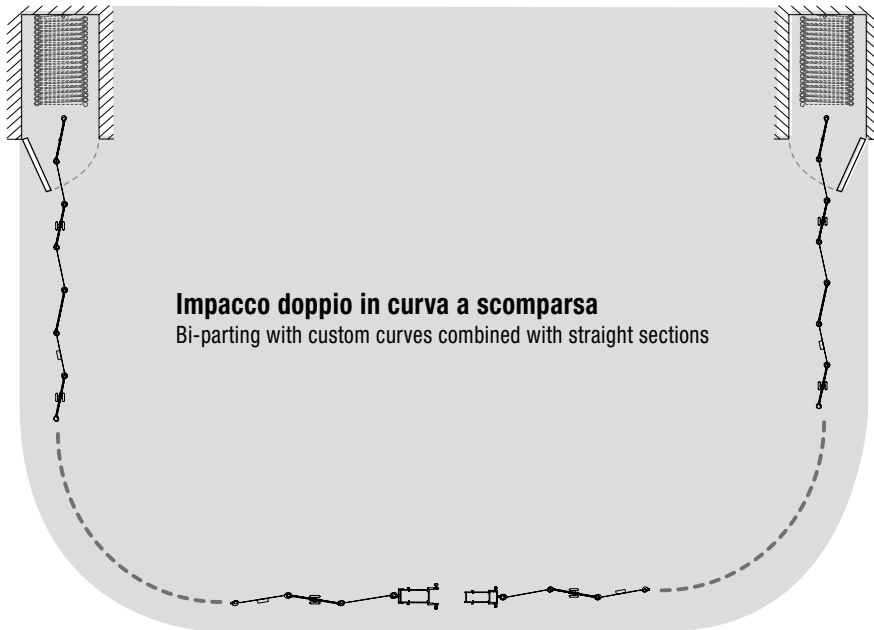

Impacco doppio in curva a scomparsa

Bi-parting with custom curves combined with straight sections

SERRANDA IMPACCHETTABILE VERTICALE

VERTICAL PACKABLE ROLLING SHUTTER

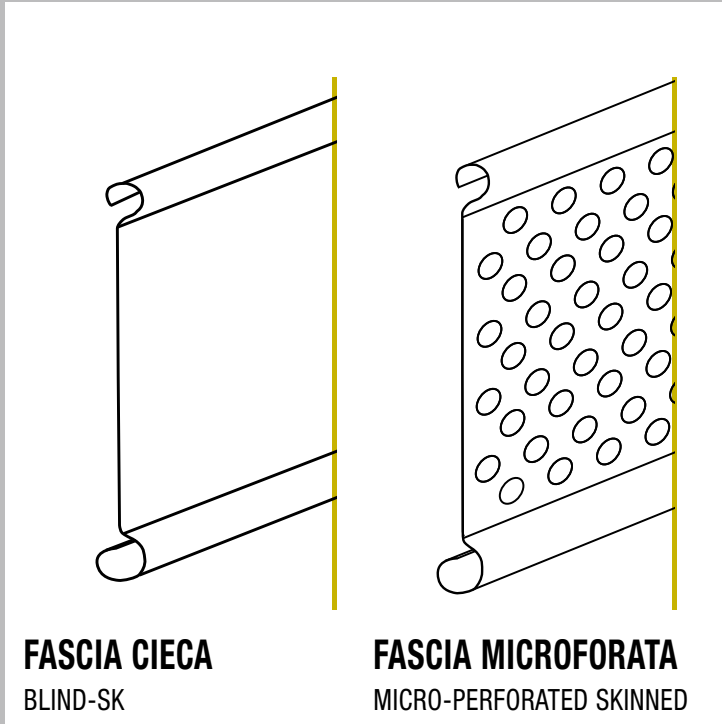

FASCIA CIECA
BLIND-SK

FASCIA MICROFORATA
MICRO-PERFORATED SKINNED

- **MODULARITÀ DI COSTRUZIONE E MONTAGGIO SEMPLIFICATO SENZA L'INTERVENTO DI MEZZI DI SOLLEVAMENTO**
- **INSTALLAZIONI SENZA LIMITI DI LARGHEZZA**
- **INGOMBRI DI APPLICAZIONE RIDOTTI AL MINIMO**
- **FINITURA STANDARD IN ACCIAIO ZINCATO A CALDO (POSSIBILITÀ DI VERNICIATURA IN QUALSIASI COLORE RICHIESTO)**
- MODULAR CONSTRUCTION AND EASY ASSEMBLY WITHOUT THE NEED FOR LIFTING MEANS
- NO WIDTH RESTRICTIONS
- OVERALL DIMENSIONS OF THE APPLICATION REDUCED TO A MINIMUM (60 X 60 MM "U" GUIDES AND 20% OF THE UPPER PART OF THE APERTURE WITH THE BARRIER FULLY RAISED)
- STANDARD FINISH IN HOT GALVANIZED STEEL (CAN BE PAINTED IN ANY COLOUR REQUIRED)



LARGHEZZA
SENZA LIMITI

WIDTH
LIMITLESS



Protezione per grandi dimensioni ad impacco superiore realizzata con profili ad alta resistenza e materiali di prima qualità. Il semplice disegno e le caratteristiche costruttive garantiscono una valida difesa antintrusione.

Può essere realizzata in acciaio pieno oppure microforato. La finitura può essere in acciaio zincato oppure verniciato, su richiesta, in qualsiasi colore.

Protection for large size ceiling-mounted telescopic, it is a packable protection made of profiles in highstrength and realized with high quality materials. The simple design and construction characteristics guarantee a valid anti-intrusion barrier. It can be made of full or microperforated steel. Finishing can be galvanized steel or painted galvanized steel, in any color.

SERRANDA A PANTOGRAFO IMPACCHETTABILE VERTICALE

VERTICAL PACKABLE ROLLING SHUTTER

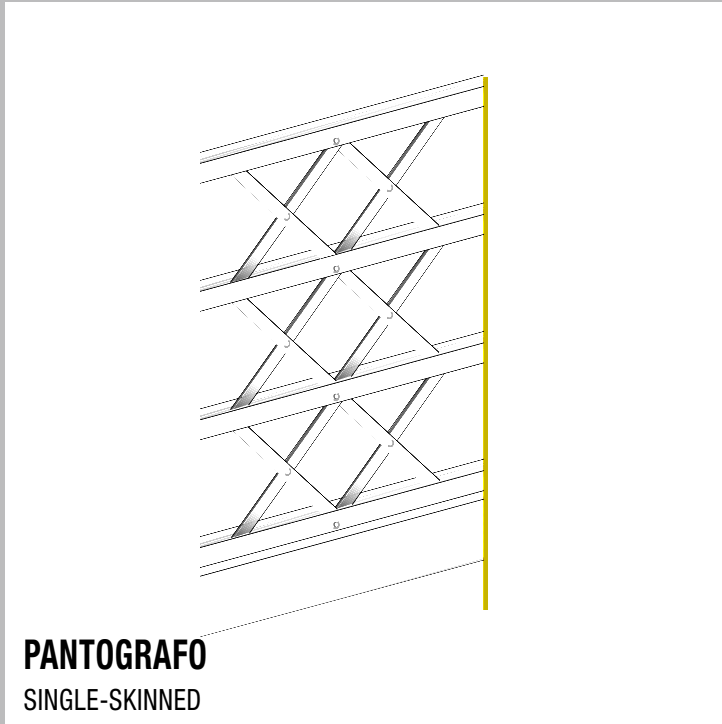

- **BARRIERE CASSA**
- **GALLERIE COMMERCIALI**
- **VETRINE DI GRANDI DIMENSIONI**
- **SUDDIVISIONE DI GRANDI AREE**

- MODULAR CONSTRUCTION AND EASY ASSEMBLY WITHOUT THE NEED FOR LIFTING MEANS
- NO WIDTH RESTRICTIONS
- OVERALL DIMENSIONS OF THE APPLICATION REDUCED TO A MINIMUM (60 X 60 MM "U" GUIDES AND 20% OF THE UPPER PART OF THE APERTURE WITH THE BARRIER FULLY RAISED)
- STANDARD FINISH IN HOT GALVANIZED STEEL (CAN BE PAINTED IN ANY COLOUR REQUIRED)

LARGHEZZA
SENZA LIMITI

WIDTH
LIMITLESS



Protezione estensibile a pantografo con profilo ad alta resistenza. La barriera modulare è una nuova chiusura per grandi dimensioni progettata nel pieno rispetto delle normative vigenti. Realizzata appositamente per i grandi spazi commerciali (chiusure di barriere casse, gallerie commerciali, vetrine di grandi dimensioni).

Protection for large size ceiling-mounted telescopic, it is a packable protection made of profiles in high strength and realized with high quality materials. The simple design and construction characteristics guarantee a valid anti-intrusion barrier. It can be made of full or microperforated steel. Finishing can be galvanized steel or painted galvanized steel, in any color.

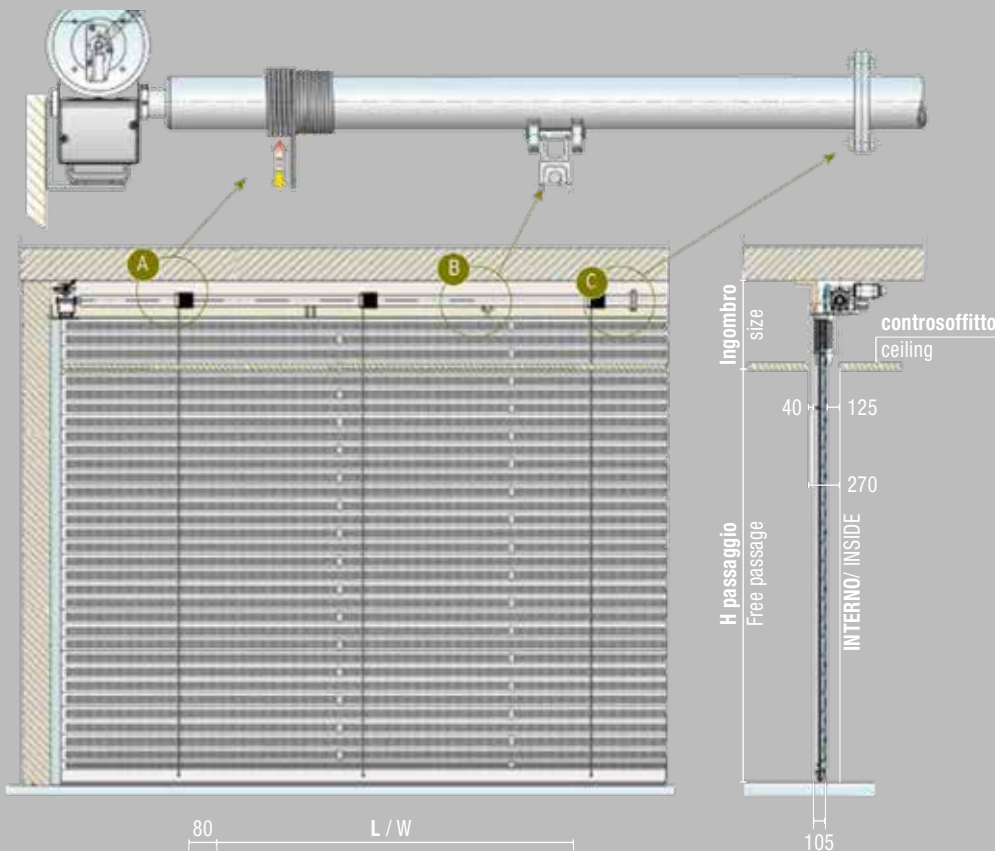

- A** Avvolgimento dei cavi su pulegge scanalate.
The winding of the cables on grooved pulleys.
- B** Cuscinetti radiali rivestiti in nylon
Nylon coated radial bearings
- C** Albero di avvolgimento assemblabile in cantiere, senza limiti di lunghezza.
Shaft assemblable on-site, without no length restrictions

Dimensioni / Dimensions	
H passaggio Free passage	Ingombro Size
3000	~ 750
3500	~ 800
4000	~ 820
4500	~ 850

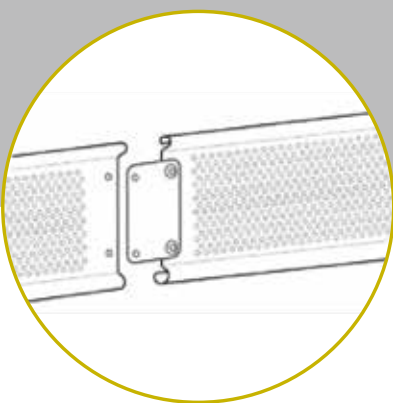

COSTRUZIONE MODULARE MODULAR CONSTRUCTION

Il telo è costruito con moduli distinti che vengono assemblati direttamente in cantiere fissando gli appositi elementi di giunzione.

Il sistema di collegamento delle diverse parti prevede gli elementi di lunghezza sfalsata in modo che ogni punto di giunzione sia rinforzato dall'inserimento nel riccio continuo dei profilati superiore ed inferiore.

The shutter is constructed from separate modules which are assembled directly on site by setting the appropriate junction elements.

The connection system of the different parts is achieved using slats with staggered length so that each junction point is reinforced by the insertion in the continuous articulation of the upper and lower sections.

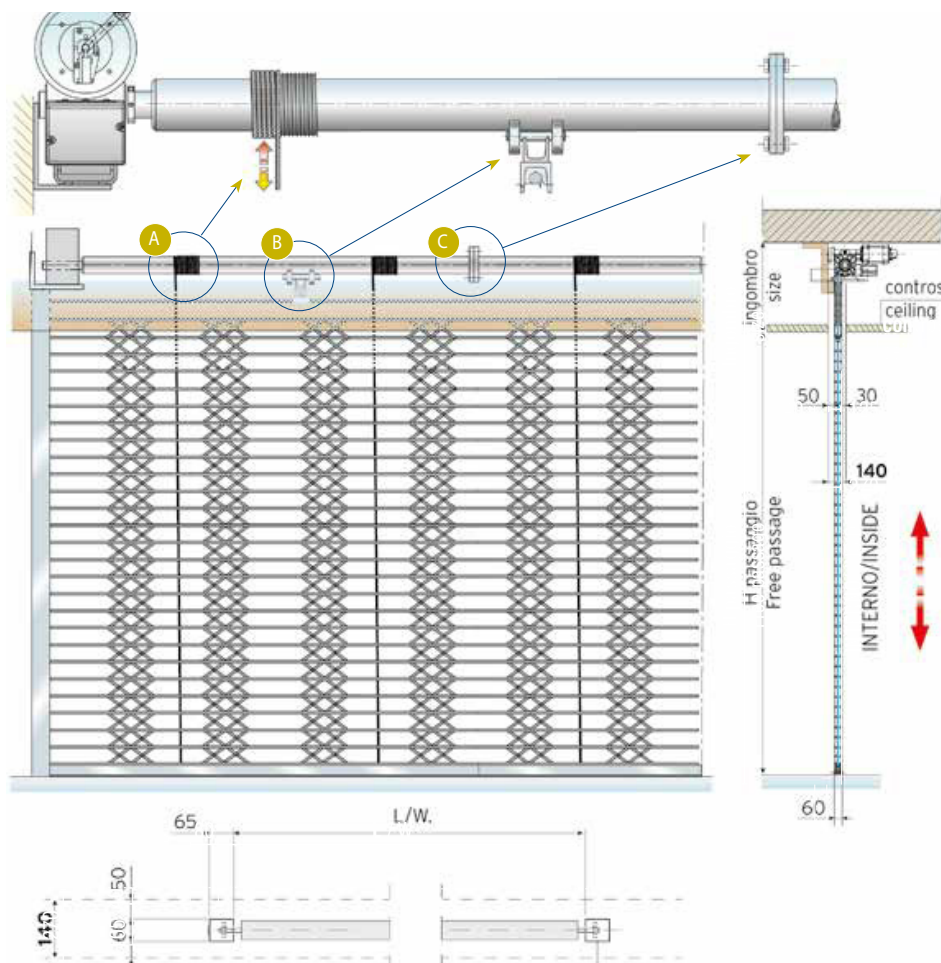

- A** Avvolgimento dei cavi su pulegge scanalate.
The winding of the cables on grooved pulleys.
- B** Cuscinetti radiali rivestiti in nylon
Nylon coated radial bearings
- C** Albero di avvolgimento assemblabile in cantiere, senza limiti di lunghezza.
Shaft assemblable on-site, without no length restrictions

Dimensioni / Dimensions

H passaggio <i>Free passage</i>	Ingombro <i>Size</i>
3000	~ 850
3500	~ 900
4000	~ 970
4500	~ 1050

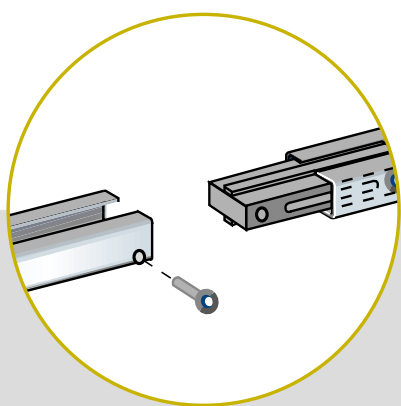

COSTRUZIONE MODULARE
MODULAR CONSTRUCTION

Telo costruito da elementi orizzontali a doppio "U" collegati da pantografi. Elemento di giunzione per il collegamento dei moduli/telo. Speciali tasselli in polizene 1000 posizionati nei punti strategici impediscono lo sfregamento del cavo su altre parti meccaniche. Telo manovrato con l'utilizzo di funi di sollevamento in acciaio zincato ad alta sicurezza. Caratteristiche prestazionali secondo la norma UNI EN 13241-1.

Shutter made from galvanized steel and consisting of double "U" horizontal bars connected by pantographs.
Joint for module/panel jointing.
Special guides in polyxene 1000 positioned in strategic points prevent the cable from rubbing against other mechanical parts
The shutter is operated by means of high-security galvanized steel lifting cables. UNI EN 13241-1 Standard performance



DOMINUS MOD. COIBENTATI / MOD. WITH POLYURETHANE INSULATION

Consulta il catalogo online.

Consult the online catalog.

FERRAROPORTE.COM/DOMINUS



MODELLO SFD

PER LE SUE QUALITÀ TROVA APPLICAZIONE IN VARI CONTESTI GRAZIE AL FUNZIONAMENTO SILENZIOSO, ECCELLENTE RESISTENZA A CONDIZIONI ESTREME E ALTE PRESTAZIONI DI ISOLAMENTO TERMICO E ACUSTICO.

Doppio profilo in alluminio 5,72 Kg/m² o acciaio zincato 12 Kg/m²

Verniciatura a polvere

Dimensione stecca 91 x 20 mm

Spessore 0,4 mm

Densità di poliuretano 57 kg/m³ (± 2kg/m³)

Numero stecche per mq 11

Certificazione approvata dal EN13241-1:

Pressione del vento CLASSE 2

Dimensione massima 10000 mm x 10000 mm

Riduzione del suono 21(-1;-2)dB

Trasmittanza termica 4,46 Up[W/(m²k)]

Temperatura massima 80°C stecca

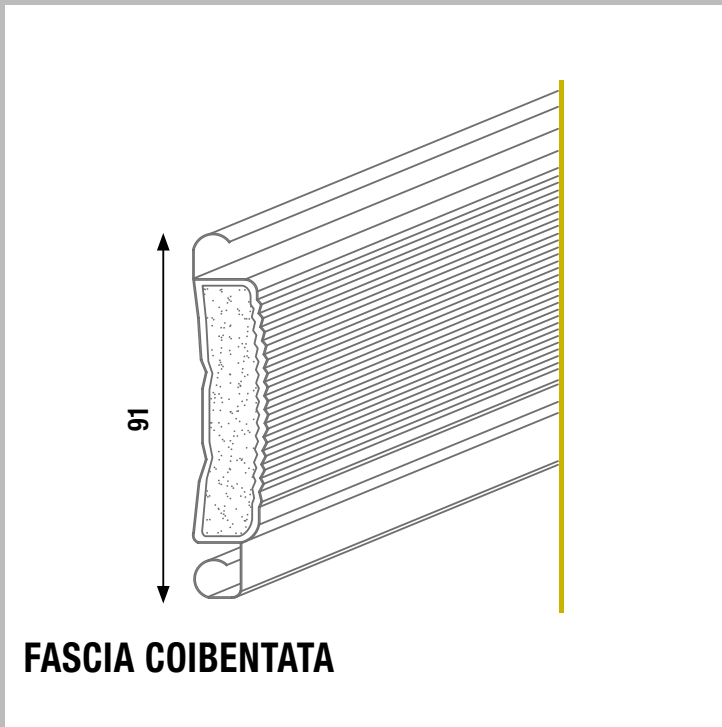

FASCIA COIBENTATA



ACCESSORI

1. Griglia e oblò in plexiglass
2. Gancio a T o a L in alluminio (resistente a spinta sia positiva che negativa)
3. Gancio a rullo in acciaio zincato (resistente a spinta sia positiva che negativa)
4. Terminale in alluminio con gomma di battuta e omega di rinforzo per larghezze superiori a 5000 mm

**RIDUZIONE
DEL SUONO
&
TRASMITTANZA
TERMICA**



Serrande DOMINUS SFDAC in acciaio coibentato verniciato a polvere con tre file di oblò 600x64.

GRIGLIE E OBLÒ SFDAC / SFDAL

Oltre ai classici profili chiusi, è possibile inserire doppio vetro in policarbonato trasparente 130 x 60 mm nel doppio profilo coibentato, oppure finestratura in plexiglass 150 x 60 mm o 600 x 64 mm con vetrino in policarbonato trasparente inserito nel profilo in alluminio estruso a parete singola di 2 mm di spessore.

Nella parte inferiore il telo è munito di terminale in alluminio estruso a con guarnizione, con applicati gommini di battuta e maniglia di sollevamento; per larghezze superiori a 5 metri si applica un elemento a V di rinforzo sul terminale.

Alle estremità laterali gli elementi sono sempre corredati di tappi di contenimento antirumore e antispostamento, e possono essere corredati di ganci antistrappo conformemente alla normativa UNI EN 13241-1 e UNI EN 12424.

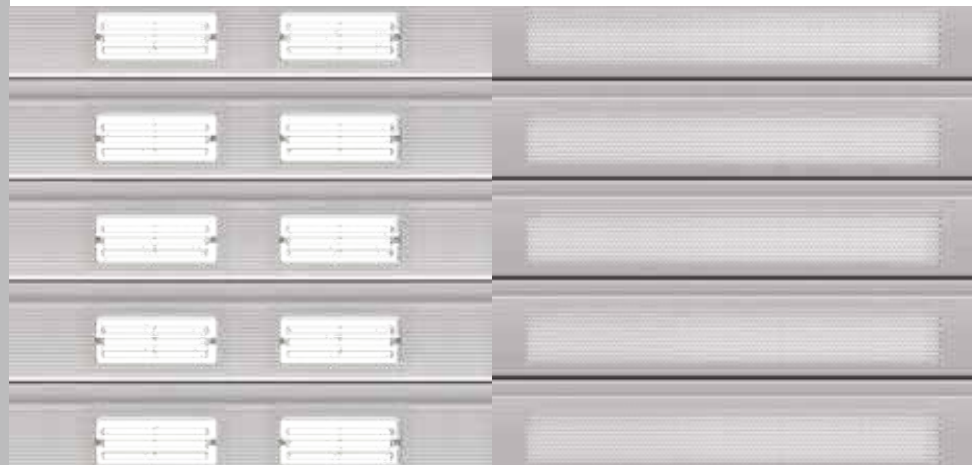
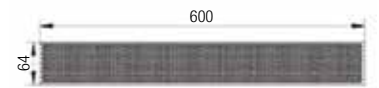
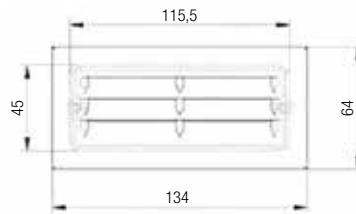

GRIGLIA 130x60 130x60 VENTILATION GRILL

Griglie 134x64 mm in doppio plexiglass per una naturale ventilazione, inserite nel profilo coibentato (max nr 4/ML).

Ventilation grills 134x64 mm from double plexiglass for a natural ventilation, placed on insulated profile (max nr 4/ML).

GRIGLIA PERFORATA PERFORATED GRILL

Griglie 600x64 mm in lamiera perforata con fori da 3 mm per una naturale ventilazione, inserite nel profilo in alluminio estruso.

Perforated Grills 600x64 mm from metal plates with 3mm holes for natural ventilation, placed on an aluminum extrusion profile.

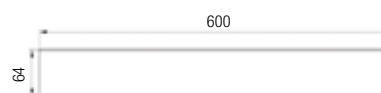
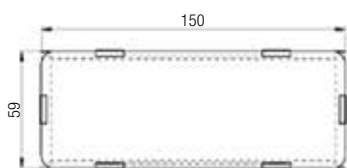
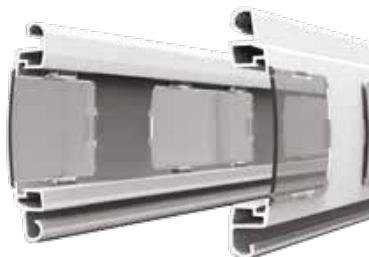
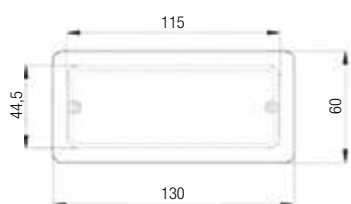

OBLÒ 130x60
130x60 WINDOW

Oblò 130x60 mm in doppio plexiglass per un passaggio naturale della luce, inserite nel profilo coibentato (max nr 4/ML).

Double Plexiglass 130x60mm windows option, for natural lighting, placed on insulated profile (max nr 4/ML).

OBLÒ 150x60
150x60 WINDOW

Oblò 150x60 mm in plexiglass per un passaggio naturale della luce, inseriti nel profilo in alluminio estruso (max nr 4/ML).

Plexiglass 150x60 mm windows on aluminum extrusion profile option, for natural lighting (max nr 4/ML).

OBLÒ 600x64
600x64 WINDOW

Oblò in plexiglass 600x64 mm per un maggiore passaggio della luce naturale, inseriti nel profilo in alluminio estruso.

Plexiglass 600x64mm windows on aluminum extrusion profile option, when additional natural lighting is required.

MODELLO SFEAC / SFEAL

SFEAC / SFEAL MODEL

CONSIGLIATA PER LA CHIUSURA DI GARAGE E CONTESTI DI PREGIO, OVE SIA NECESSARIO IL MINIMO IMPATTO DI RUMOROSITÀ, E UN GRADEVOLE IMPATTO VISIVO. IL PROFILO COIBENTATO CONTRIBUISCE AD AUMENTARE L'ISOLAMENTO TERMICO TRA ESTERNO E INTERNO.

RECOMMENDED FOR GARAGES CLOSURE AND ELEGANT CONTEXTS, WITH A MINIMUM NOISE AND GREAT DESIGN. THE INSULATED PROFILE HELPS TO INCREASE THE THERMAL INSULATION BETWEEN OUTSIDE AND INSIDE.

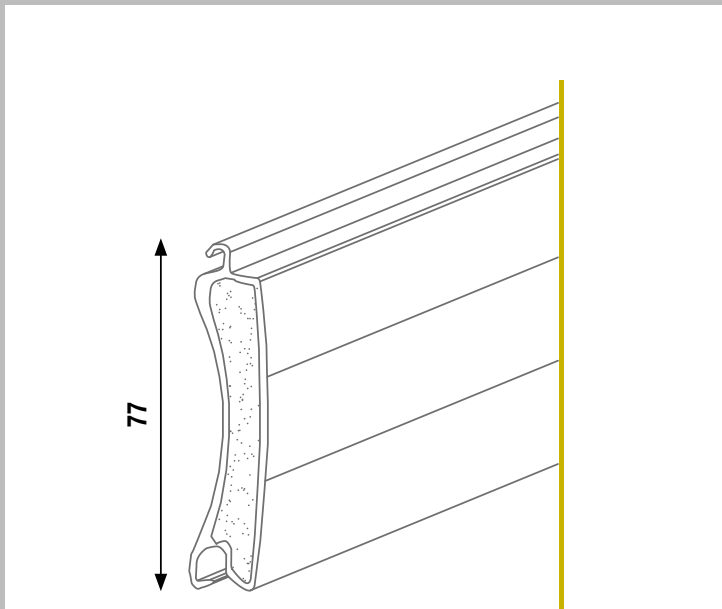

FASCIA COIBENTATA

SINGLE PROFILE WITH POLYURETHANE INSULATION

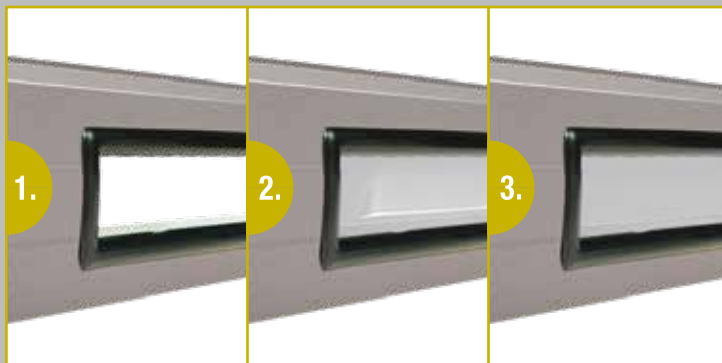

DISPONIBILE IN 2 TIPOLOGIE:

2 TYPES AVAILABLE:

SFEAL	SFEAC
6 Kg/m ²	11,5 Kg/m ²

ACCESSORI

1. Oblò forato con guarnizione nera
2. Oblò areatore con guarnizione nera
3. Oblò trasparente con guarnizione nera
4. Gancio a rullo in acciaio zincato
5. Terminale in alluminio con gomma di battuta

ACCESSORIES

1. Perforated window with black frame
2. Ventilation window with black frame
3. Transparent window with black frame
4. ROLLING hook in galvanized steel
5. Aluminum terminal with stop rubber

**CONTENIMENTO
COSTI ENERGETICI**

**CONTAINING
ENERGY COSTS**



Serranda DOMINUS SFEAC in acciaio coibentato, colore finto legno.
DOMINUS SFEAC rolling shutter with polyurethane insulation steel, imitation wood color.

La serranda DOMINUS ELEGANT è disponibile nei modelli SFEAC in acciaio preverniciato e SFEAL in alluminio coibentati con schiuma poliuretana ad alta stabilità e lunga durata. Grazie alla sua compattezza ben si presta alla chiusura di capannoni industriali e autosaloni.

DOMINUS ELEGANT rolling shutter is available in SFEAC models in pre-painted steel and aluminum SFEAL insulated with high stability and long life polyurethane foam. Thanks to its compactness, it is suitable for closing industrial sheds and car showrooms.



FERRARO
UNA PORTA SUL

FERRARO

DOMINUS SERRANDA VELOCE / SPEED SHUTTER

Consulta il catalogo online.

Consult the online catalog.

FERRAROPORTE.COM/DOMINUS



SERRANDA VELOCE

HIGH SPEED SHUTTER

LA SERRANDA INDUSTRIALE AD AVVOLGIMENTO RAPIDO, CON FASCIA SFDAC, È STATA STUDIATA E PRODOTTA PER RISPONDERE ALL'ESIGENZA DI MERCATO DI UN PRODOTTO CHE PRESENTI MOLTEPLICI VANTAGGI:

1. UNICA CHIUSURA CHE SOSTITUISCE IL BINOMIO SERRANDA NORMALE + PORTA RAPIDA
2. RAPIDITÀ
3. EFFICIENZA ENERGETICA
4. VANTAGGIO TECNOLOGICO
5. RENDIMENTO ECONOMICO

THE SPEED INDUSTRIAL ROLLING SHUTTER, WITH SFDAC PROFILE, HAS BEEN DESIGNED TO MEET THE MARKET REQUIREMENTS, IT IS A PRODUCT THAT HAS MANY ADVANTAGES, LIKE:

1. SINGLE CLOSURE THAT REPLACES THE COMBINATION OF NORMAL SHUTTER + RAPID DOOR
2. RAPIDITY
3. ENERGY EFFICIENCY
4. TECHNOLOGICAL ADVANTAGE
5. ECONOMIC PERFORMANCE

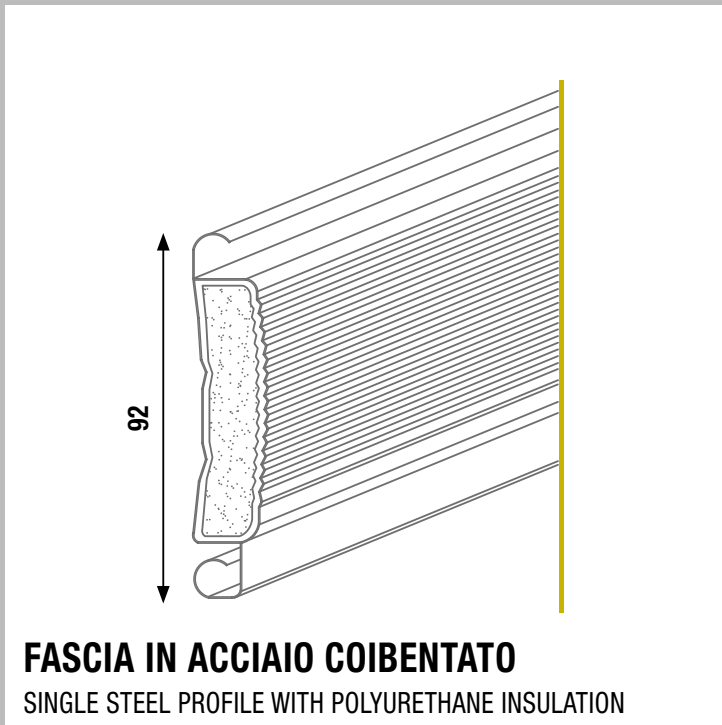

FASCIA IN ACCIAIO COIBENTATO

SINGLE STEEL PROFILE WITH POLYURETHANE INSULATION



MENSOLE SCORREVOLE

Sistema a mensole scorrevoli che consentono il movimento trasversale del manto.

SLIDING SIDE FRAMES

Sliding shelf system that allows the transversal movement of the covering.

**VELOCITÀ
FINO A 2 m/s**

**SPEED UP
TO 2 m/s**



L'innovazione più grande apportata dalla serranda è l'avvolgimento rapido per ridurre i tempi di apertura e chiusura, che consente di mantenere le prestazioni termiche e di migliorare il flusso dei veicoli. Sono state utilizzate motorizzazioni ad inverter, che consentono la regolazione della velocità in maniera differente in salita e discesa, utilizzando rampe di accelerazione e decelerazione.

The biggest innovation brought by the shutter is the rapid winding to reduce opening and closing times, which allows you to maintain thermal performance and improve vehicle flow. Inverter motors were used, which allow the speed to be regulated differently when ascending and descending, using acceleration and deceleration ramps.



DOMINUS GUIDE E ACC. / GUIDES AND ACCESSORIZES

Consulta il catalogo online.

Consult the online catalog.

FERRAROPORTE.COM/DOMINUS



GUIDE DI SCORRIMENTO

SLIDING GUIDES

LE GUIDE DI SCORRIMENTO SONO REALIZZATE CON PROFILI DI ACCIAIO ZINCATO DI ADEGUATO SPESSORE, E LA PROFONDITÀ DELLA GUIDA È FUNZIONE DELLA LARGHEZZA DELLA SERRANDA. LE GUIDE SONO MUNITE DI GUARNIZIONI IN COESTRUSO ANTIRUMORE E NELLA PARTE SUPERIORE DI PROFILO COMPENSATORE CON SPAZZOLINO CHE CREA UNA TENUTA TRA L'ARCHITRAVE E LA SERRANDA. L'ANCORAGGIO AVVIENE TRAMITE STAFFE DA FISSARE CON ANCORANTI MECCANICI.

THE SLIDING GUIDES ARE MADE WITH GALVANIZED STEEL PROFILES OF ADEQUATE THICKNESS, THE GUIDE DEPTH IS A FUNCTION BY THE WIDTH OF THE SHUTTER. THE GUIDES ARE EQUIPPED WITH ANTI-NOISE CO-EXTRUDED GASKETS AND IN THE UPPER PART OF A COMPENSATOR PROFILE WITH A BRUSH THAT CREATES A SEAL BETWEEN THE LINTEL AND THE SHUTTER. THE ANCHORAGE IS USED WITH BRACKETS TO BE FIXED WITH MECHANICAL ANCHORS.

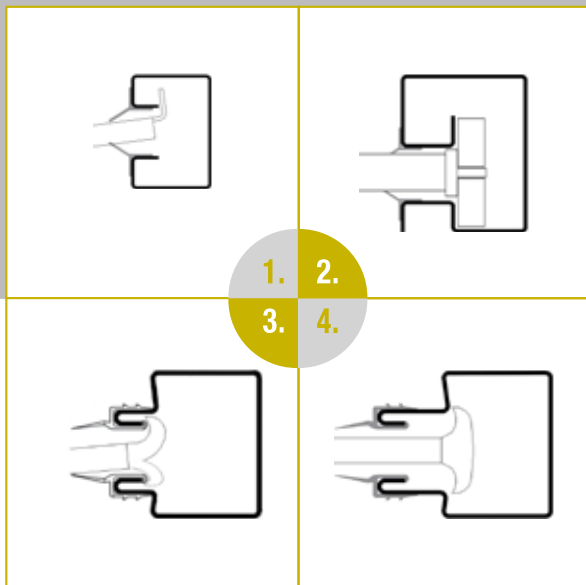

1. Il gancio a L scorre solo nella guida C50
2. Il gancio a rullo scorre solo nelle G80, G80S e G95
3. Il gancio a L scorre solo nelle guide 80/95
4. Il gancio a T scorre solo nelle guide 80/95

1. L hook slides in guide C50 only
2. Rolling hook slides in G80, G80S e G95 only
3. L hook slides in guides 80/95 only
4. T hook slides in guides 80/95 only



APPLICAZIONE DIETRO MAZZETTA APPLICATION BEHIND THE WALL

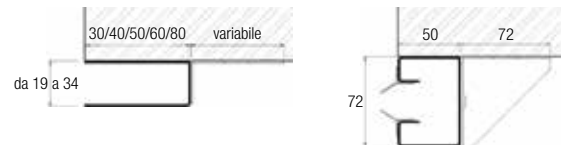

APPLICAZIONE IN LUCE APPLICATION BETWEEN THE WALL

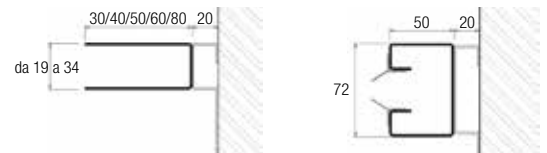

PROFILO COMPENSATORE BRUSH

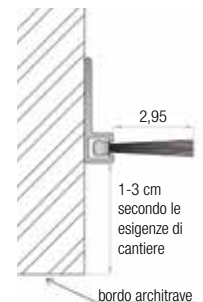

**GUIDA U 30/40/50/60/80
staffa dietro mazzetta a
richiesta per LIVING
(guarnizione a richiesta)**

U GUIDE
30/40/50/60/80
support onto the wall
on request for LIVING
(gasket on request)

**GUIDA C50
con guarnizione,
staffa dietro mazzetta
e profilo compensatore
a richiesta per LIVING**

GUIDE C50
with gasket,
support onto the wall
and brush
on request for LIVING

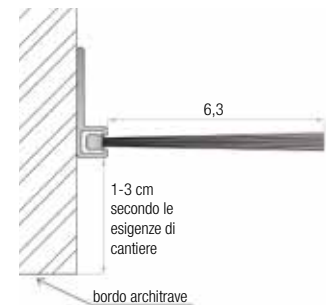
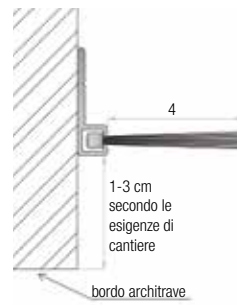
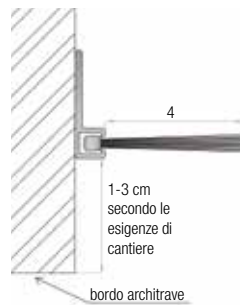
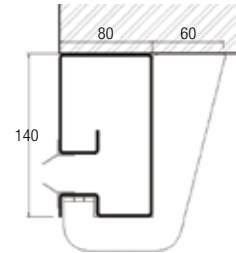
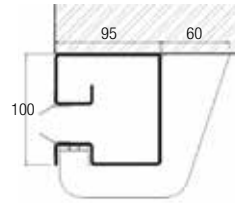
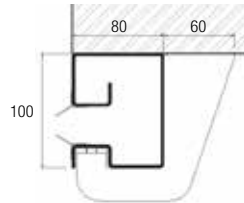
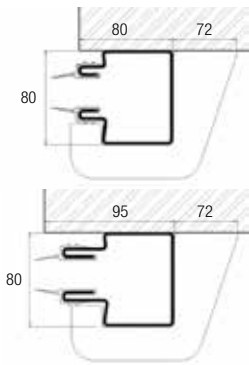

GUIDE 80/95
solo per SFDAC/SFDAL,
con guarnizione e
staffa dietro mazzetta

GUIDA G80
con guarnizione,
staffa dietro mazzetta
e profilo compensatore

GUIDA G95
con guarnizione,
staffa dietro mazzetta
e profilo compensatore

GUIDA G80 SPESORIZZATA
con guarnizione,
staffa dietro mazzetta
e profilo compensatore

GUIDE OMEGA 80/95
for SFDAC/SFDAL only,
with gasket and support
onto the wall

GUIDE G80
with gasket,
support onto the wall
and brush

GUIDE G95
with gasket,
support onto the wall
and brush

THICKENED GUIDE G80
with gasket,
support onto the wall
and brush

NEW

SCATOLA PORTA MOLLA APRIBILE

OPENING SPRING HOLDER BOX

La scatola porta molle rappresenta un componente cruciale nei sistemi di serrande, offre una grande facilità di installazione.

Trova il suo massimo impiego nel contesto delle riparazioni e delle sostituzioni, consentendo il montaggio agevolato senza la necessità di smontare l'albero, grazie allo sgancio di due singoli bulloni.

The spring box is a crucial component in shutter systems, offering great ease of installation.

It finds its maximum use in the context of repairs and replacements, allowing easy assembly without the need to disassemble the shaft, thanks to the release of two single bolts.



Codice Code	Diametro Interno Inner Diameter	Diametro Esterno Outer Diameter	Larghezza Width
2161582-1	ø 48 mm	ø 200 mm	60 mm
2161583-1	ø 60 mm	ø 200 mm	60 mm
A RICHIESTA	ø 48 mm	ø 220 mm	60 mm
2161580-1	ø 60 mm	ø 220 mm	60 mm
2161581-1	ø 76 mm	ø 240 mm	60 mm

NEW

270168-102 CARICA MOLLE MANUALE MANUAL SPRING CHARGER

Attrezzo per caricare/scaricare la molla in sicurezza

Tool for loading/unloading the spring safely

Si aggancia alla scatola e ne aziona la rotazione

Attaches to the box and activates its rotation

Adatto a scatole porta molla per tubo

Suitable for spring boxes for tube

Lancetta contagiri inclusa

Tachometer needle included

Chiave a bussola esagonale da 10 per avvitatore

10 Hex socket wrench for screwdriver

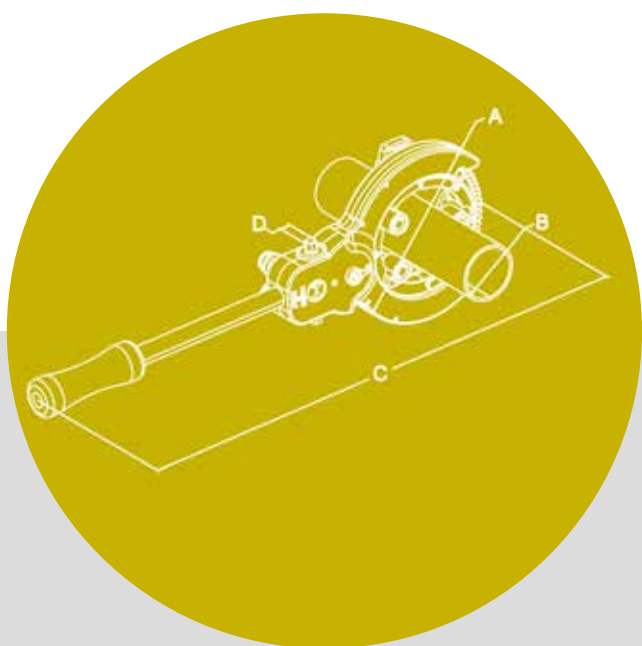

A (mm)	B (mm)	C (mm)	D (mm)	KG
185	42	550	10	3,8
185	48	550	10	3,8
185	60	550	10	3,8
185	76	550	10	3,8

Funzionamento facile e veloce con avvitatore/trapano (non incluso)

Quick and easy operation with
screwdriver/drill (not included)



CASSONETTI

BOX

CASSONETTO LIVING IN LAMIERA ZINCATA (A RICHIESTA VERNICIATA O RIVESTITA) PER INTERNO O ESTERNO

BOX "LIVING" IN GALVANIZED SHEET (PAINTED OR COATED ON REQUEST) FOR INSIDE OR OUTSIDE.



CASSONETTO LIVING

BOX "LIVING"

CASSONETTO TIME IN LAMIERA ZINCATA (A RICHIESTA VERNICIATA O RIVESTITA) PER INTERNO O ESTERNO (PER APPLICAZIONE ESTERNA AGGIUNGERE CARTER COPRIMOTORE)

BOX "TIME" IN GALVANIZED SHEET (PAINTED OR COATED ON REQUEST) FOR INSIDE OR OUTSIDE (FOR OUTDOOR APPLICATION ADD MOTOR CARTER)



CASSONETTO TIME

BOX "TIME"

CARTER

COPRI MOTORE E COPRI CUSCINETTO PER SERRANDE ESPOSTE AGLI AGENTI ATMOSFERICI

MOTOR COVER AND BEARING COVER FOR SHUTTERS EXPOSED TO ATMOSPHERIC AGENTS



CASSONETTI, ORNIE E VELETTE

SYSTEM COVER, FRAME EXTENSIONS AND UPPER COVERS

I cassonetti nascono con l'obiettivo di proteggere l'intero asse, evitando l'inserimento di corpi estranei, e migliorando al contempo l'estetica interna della serranda. La veletta risulta, invece, necessaria quando l'altezza dell'architrave è insufficiente a nascondere il gruppo asse. Infine, quando le murature non sono a perfetta regola d'arte (fuori piombo, con bordi irregolari, ecc..) vengono fornite le ornìe, cioè lamierati pressopiegati che compensano e/o nascondono le imperfezioni della muratura.

The boxes are designed to protect the entire axis, avoiding the insertion of foreign bodies, and at the same time improving the internal aesthetics of the shutter. The upper cover is, however, necessary when the height of the architrave is insufficient to hide the axis group. Anyway, when the walls are not in a perfect workmanlike manner (out of plumb, with irregular edges, etc.) we supply press-folded sheet metal which compensates and/or hides the imperfections of the masonry.

VELETTE

UPPER COVERS

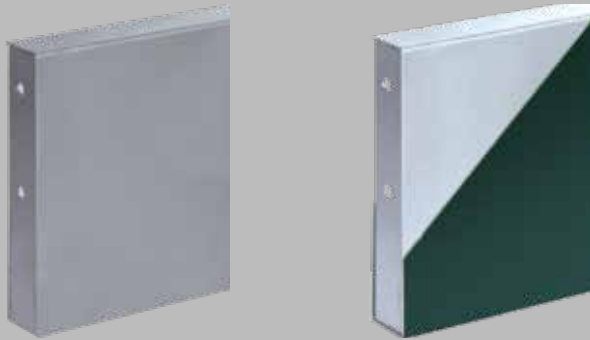

**VELETTA PRESSOPIEGATA
IN ACCIAIO ZINCATO
(A RICHIESTA: VERNICIATA O RIVESTITA
IN LAMIERA DELLO STESSO COLORE
DELLA FASCIA, FINITURA LISCIA)**

GALVANIZED STEEL PRESS-FOLDED VELETTA
(ON REQUEST: PAINTED OR COATED IN SHEET METAL
OF THE SAME COLOR OF THE BAND, SMOOTH FINISH)

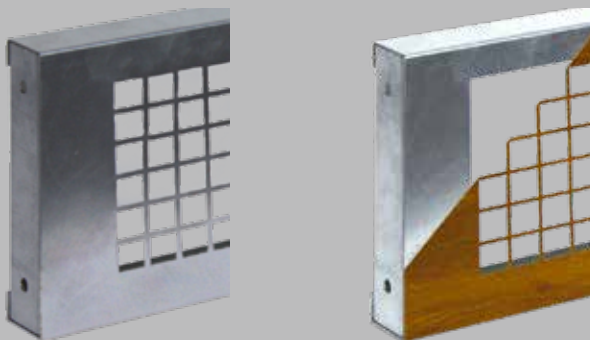

**VELETTA PRESSOPIEGATA IN ACCIAIO
FORATA QUADRO 20X20 MM
(A RICHIESTA: VERNICIATA O RIVESTITA
IN LAMIERA DELLO STESSO COLORE
DELLA FASCIA, FINITURA LISCIA)**

UPPER COVER PRESSED IN 20X20 MM PERFORATED
SQUARE STEEL (ON REQUEST: PAINTED OR COVERED
IN SHEET OF THE SAME COLOR OF THE BAND,
SMOOTH FINISH)

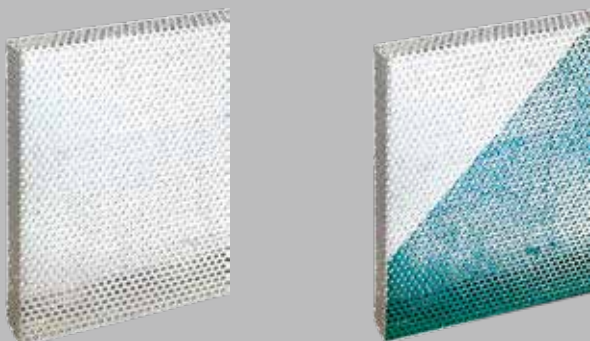

**VELETTA IN LAMIERA ACCIAIO
MICROFORATA ZINCATA
(VERNICIATA A RICHIESTA)**

UPPER COVER IN GALVANIZED MICRO-PERFORATED
STEEL SHEET (PAINTED ON REQUEST)

ORNIE

FRAME EXTENSIONS

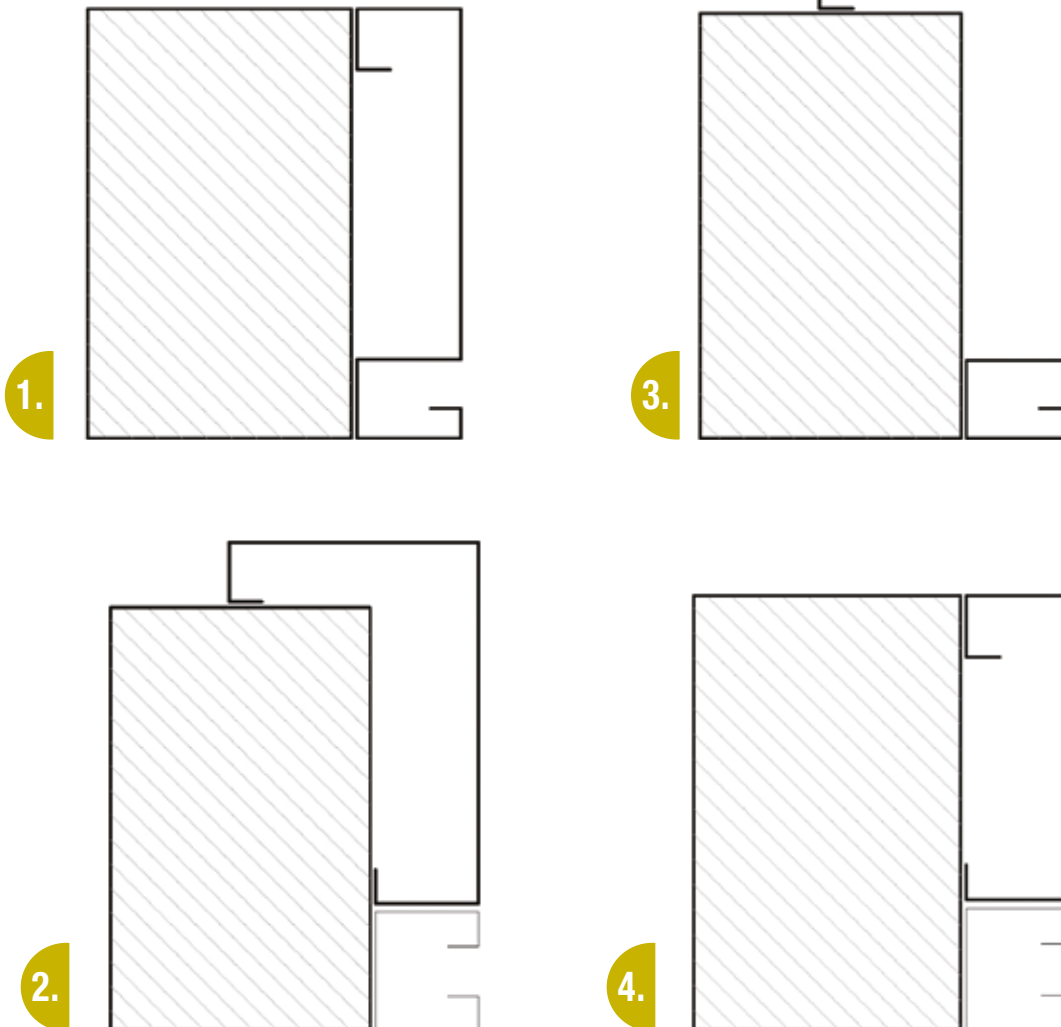

ASSEMBLAGGIO MECCANICO

MECHANICAL ASSEMBLY

Da preferire quando l'ornia è verniciata e per evitare saldature in cantiere. Fino a 6000 mm di larghezza/altezza.

Preferable when the ornament is painted and to avoid welding on site. Up to 6000 mm wide / height.

- 1. Ornina in luce non assemblata meccanicamente**
Frame extensions in light not punched
- 2. Ornina oltre luce non assemblata meccanicamente**
Frame extensions beyond light not punched
- 3. Ornina assemblata meccanicamente in luce non saldata in cantiere**
Frame extensions mechanically assembled in light not welded on site
- 4. Ornina assemblata meccanicamente oltre luce non saldata in cantiere**
Frame extensions mechanically assembled over light not welded on site

SERRATURE LOCKS



Possibilità di chiavi unificate
Possibility of unified keys



1. Campana con lucchetto
Dome padlock
COD. 3231412

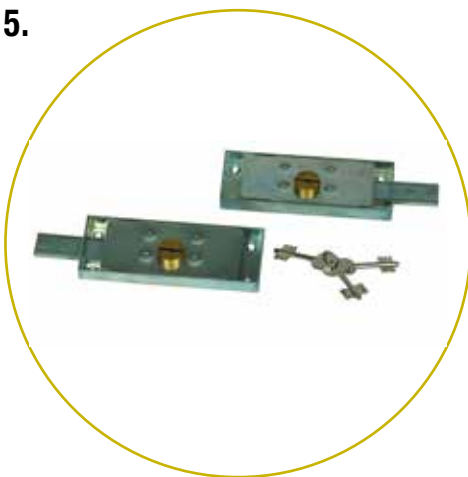
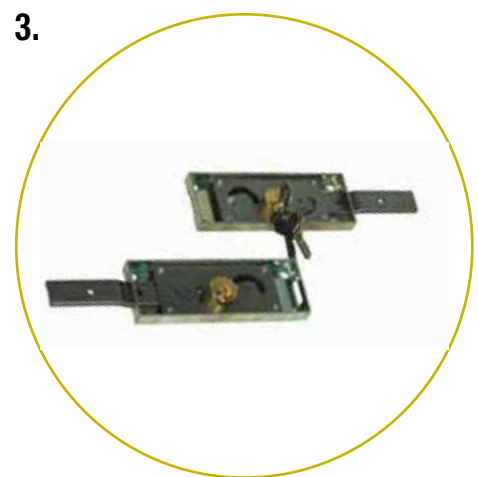
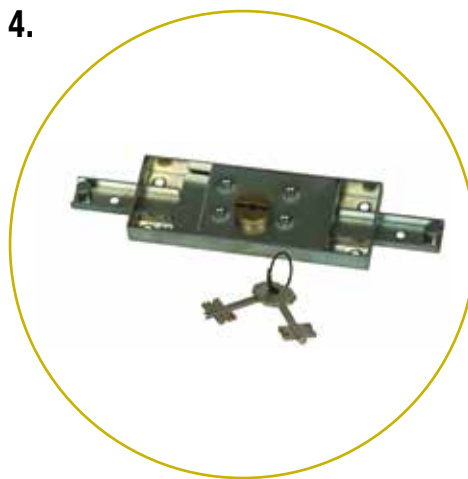
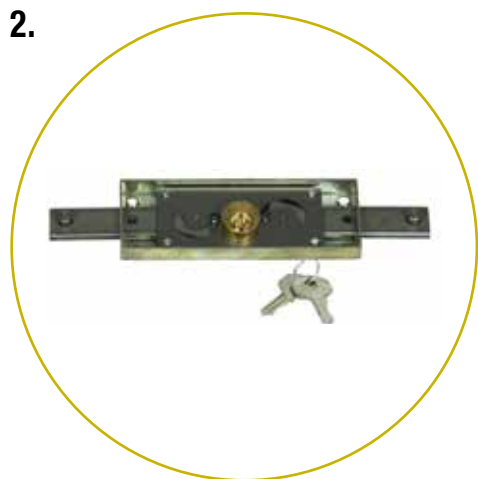

2. Serratura centrale

Central lock

COD. A21SC (SF-SFA)

COD. A21SCP (SFEAC-SFEAL

serratura decentrata / decentralized lock)

COD. A21SCDP (SFDAC-SFDAL)

3. Serratura centrale a doppia mappa

Double bit central lock

COD. A21SCDMA (SF-SFA)

4. Serratura laterale

Lateral lock

COD. A21SL (SF-SFA)

COD. A21SLP (SFEAC-SFEAL)

COD. A21SLDP (SFDAC-SFDAL)

5. Serratura laterale a doppia mappa

Double bit lateral lock

COD. A21SLDM (SF-SFA)



DOMINUS MOT. COASSIALI LIVING / LIVING COAXIAL MOT.

Consulta il catalogo online.

Consult the online catalog.

FERRAROPORTE.COM/DOMINUS





AUTOMAZIONI COASSIALI O TUBOLARI LIVING

LIVING COAXIAL MOTORIZATIONS

LA MOTORIZZAZIONE COASSIALE È ADOTTATA PER SERRANDE DI PICCOLE E MEDIE DIMENSIONI, A BASSA FREQUENZA DI UTILIZZO. SI APPLICA CON FACILITÀ AL CENTRO DELL'ASSE, SUL QUALE RUOTANO LE SCATOLE PORTAMOLLE. A RICHIESTA TUTTI I MODELLI DI MOTORIZZAZIONE POSSONO ESSERE FORNITI DI BLOCCO ELETTROMAGNETICO CHE PERMETTE L'APERTURA E LA CHIUSURA DELLA SERRANDA SENZA INTERVENIRE SULLA SERRATURA A CHIAVE.

THE COAXIAL MOTORIZATION IS ADOPTED FOR SHUTTERS OF SMALL AND MEDIUM DIMENSIONS, WITH LOW FREQUENCY OF USE. IT APPLIES EASILY TO THE CENTER OF THE AXIS, ON WHICH THE SPRING BOXES ROTATE. ON REQUEST, ALL MOTORIZATION MODELS CAN BE SUPPLIED WITH ELECTROMAGNETIC BLOCK THAT ALLOWS THE OPENING AND CLOSING OF THE SHUTTER WITHOUT INTERVENTION ON THE KEY LOCK.

COMPONENTISTICA

1. Scatole porta molla
2. Albero
3. Motorizzazione coassiale
4. Guide con bandiera
5. Selettore a chiave
6. Cavo di collegamento

COMPONENTS

1. Spring boxes
2. Shaft
3. Central motor
4. Guides with plate
5. Key switch
6. Connecting cable



Le serrande Dominus, possono essere bilanciate con motori MADE IN ITALY. Sono generalmente del tipo coassiale ma a richiesta si possono applicare motori tubolari. Per il funzionamento automatico vengono fornite le sicurezze incassate (fotocellule; barriere).

Dominus shutters can be balanced with MADE IN ITALY motors. They are generally of the coaxial type but tubular motors can be applied on request. For automatic operation, built-in safety devices (photocells; barriers) are supplied.

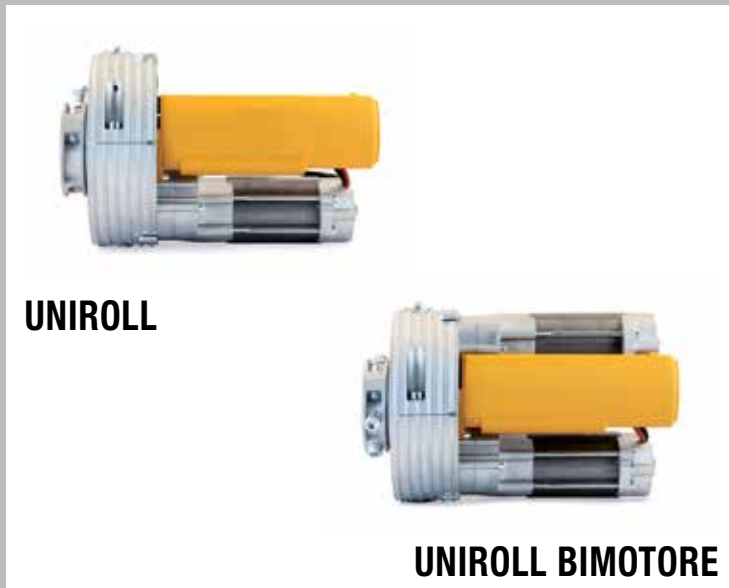

UNIROLL

UNIROLL BIMOTORE

MOTORI CENTRALI PER SERRANDE FINO A UN PESO DI 300 KG. DISPONIBILI IN DUE MODELLI IN FUNZIONE DELLE DIMENSIONI E DEL PESO DELLE SERRANDE: A 1 MOTORE E BIMOTORE. TRAMITE I SELETTORI CON SBLOCCO, È POSSIBILE SBLOCCARE IL MOTORE IN CASO DI MANCANZA DI ENERGIA ELETTRICA, CONSENTENDO L'APERTURA MANUALE DELLA SERRANDA.

CENTRAL MOTORS ARE SUITABLE FOR ALL SHUTTERS UP TO A WEIGHT OF 300 KG. ARE AVAILABLE IN TWO MODELS, ACCORDING TO THE DIMENSIONS AND WEIGHTS OF THE SHUTTERS: 1 MOTOR AND BI-MOTOR. THROUGH THE KEY SELECTORS IT IS POSSIBLE TO RELEASE THE MOTOR IN THE EVENT OF A LACK OF ELECTRICITY, ALLOWING THE MANUAL OPENING OF THE SHUTTER.

**KIT OPZIONALI PER RENDERE LE SERRANDE AUTOMATICHE:
OPTIONAL KIT TO MAKE AUTOMATIC SHUTTERS:**

- COD. 271563** **Fotocellule No Touch Fadini** / Fadini photocells No Touch
- COD. 271566** **Fotocellule No Touch Ferraro** / Ferraro photocells No Touch
- COD. 271565** **Fotocellule No Touch SEAV** / SEAV photocells No Touch
- COD. 271562** **Fotocosta Fadini** / Fadini optical safety contact strip
- COD. 271973** **Fotocosta Ferraro** / Ferraro optical safety contact strip
- COD. 271975** **Fotocosta Seav** / Seav optical safety contact strip



KIT DI SBLOCCO

COD. 280647-2
Blocco elettromagnetico
Electrobrake

COD. 280647-3
Selettore a chiave incassato
Key switch

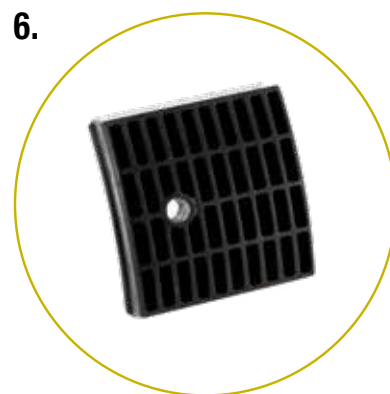

PULSANTIERE E SELETTORI
PUSHBUTTONS AND SELECTORS

1. COD. 280647-3
Selettore a chiave incassato
Key switch flush-mounted

2. COD. 280647-4
Selettore a chiave sovrapposto
Key switch surface-mounted

3. COD. 280647-1
Cassetta di blocco sovrapposta
Flush mounted selector with key door

4. COD. 280647-9
Cassetta a sportello con sblocco incassata
Door box with built-in release

ACCESSORI VARI
VARIOUS ACCESSORIES

5. COD. 280647- 5
Espansione flangia da 200 a 220
Kit flange adaptor from 200 to 220

6. COD. 280647-6
Espansione flangia da 240 a 280
Kit flange adaptor from 240 to 280

7. COD. 280647-7
Manicotto di riduzione 60-42
Tube adaptor 60-42

7. COD. 280647-8
Manicotto di riduzione 60-48
Tube adaptor 60-48



**UNIKO 1M
EVOLUTION**

**UNIKO 2M
EVOLUTION**

MOTORI CENTRALI ADATTABILI A TUTTE LE SERRANDE BILANCIATE CON MOLLE. FINO A UN PESO DI 400 KG DISPONIBILI IN DUE MODELLI IN FUNZIONE DELLE DIMENSIONI E DEL PESO DELLE SERRANDE: A 1 MOTORE E BIMOTORE. TRAMITE I SELETTORI CON SBLOCCO, È POSSIBILE SBLOCCARE IL MOTORE IN CASO DI MANCANZA DI ENERGIA ELETTRICA, CONSENTENDO L'APERTURA MANUALE DELLA SERRANDA.

CENTRAL MOTORS SUITABLE FOR ALL ROLLING SHUTTERS WITH BALANCED SPRINGS. UP TO 400 KG WEIGHT AVAILABLE IN TWO MODELS ACCORDING TO THE DIMENSIONS AND WEIGHT OF SHUTTERS: WITH 1 MOTOR AND BI-MOTOR. BY KEY SELECTORS WITH RELEASE, IT IS POSSIBLE TO UNLOCK THE MOTOR IN CASE OF ELECTRIC POWER, ALLOWING THE MANUAL OPENING OF THE SHUTTER.

**KIT OPZIONALI PER RENDERE LE SERRANDE AUTOMATICHE:
OPTIONAL KIT TO MAKE AUTOMATIC SHUTTERS:**

- | | |
|--------------------|---|
| COD. 271563 | Fotocellule No Touch Fadini / Fadini photocells No Touch |
| COD. 271566 | Fotocellule No Touch Ferraro / Ferraro photocells No Touch |
| COD. 271565 | Fotocellule No Touch SEAV / SEAV photocells No Touch |
| COD. 271562 | Fotocosta Fadini / Fadini optical safety contact strip |
| COD. 271973 | Fotocosta Ferraro / Ferraro optical safety contact strip |
| COD. 271975 | Fotocosta Seav / Seav optical safety contact strip |



COD. 270156-3 SELECTIVE

Kit di sblocco

Release Kit

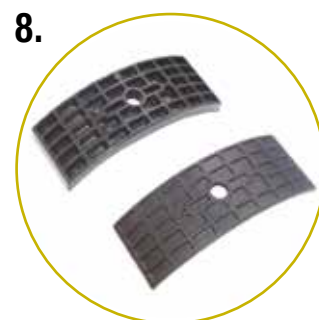
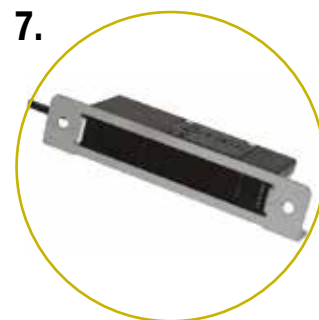

PULSANTIERE E SELETTORI
PUSHBUTTONS AND SELECTORS

1. COD. 270156-49
Pulsantiera per interni a parete
standard per il kit uomo presente
Switch panel for indoor. standard for U.P. kit

2. COD. 270156-84
Selettore a cilindro europeo
per esterni (su ordinazione)
Outdoor key selector (on request)

3. COD. 270156-11
Selettore a chiave sovrapposto
(a magazzino)
Key selector (in stock)

4. COD. 270156-15
Cassetta a sportello con sblocco sovrapposta
Built in safe with brake release

5. COD. 270156-4
Cassetta a sportello con sblocco incassata
Metal encased push button with brake release

ACCESSORI VARI
VARIOUS ACCESSORIES

6. COD. 270156-3
Blocco elettromagnetico
Electrobrake

7. COD. 270156-81 SENSITIVE
Sensore di sicurezza per serratura
Safety contractor

8. COD. 270156-5
Kit espansore flangia Uniko
da Ø200mm a Ø220mm
Kit flange adaptor Uniko
from Ø200mm to Ø220mm

9. COD. 270156-8
Riduzione Uniko da Ø60 a Ø48
Tube adaptor Uniko from Ø60 to Ø48



DOMINUS MOT. LATERALI TIME / TIME SIDE MOT.

Consulta il catalogo online.

Consult the online catalog.

FERRAROPORTE.COM/DOMINUS



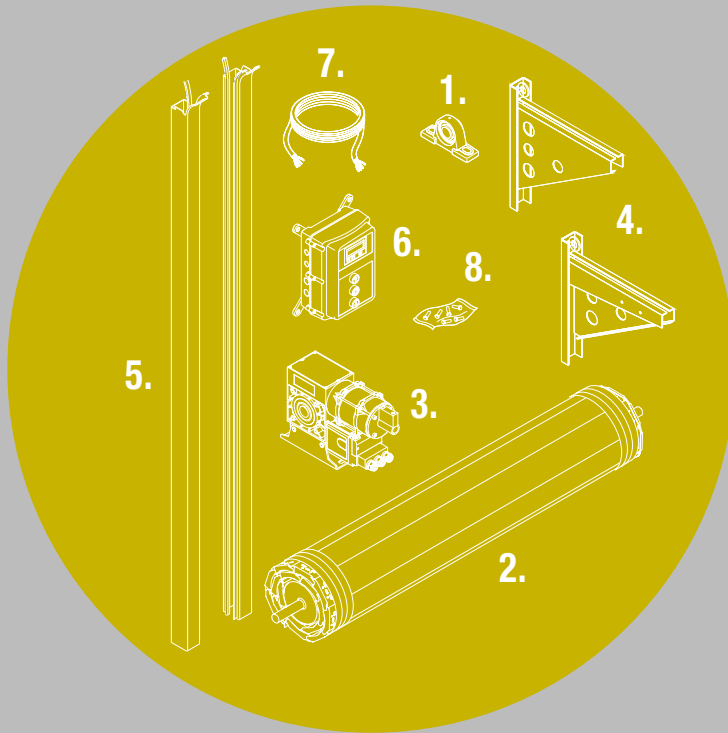

AUTOMAZIONI LATERALI TIME

TIME SIDE MOTORIZATIONS

LA CARATTERISTICA DELLE SERRANDE INDUSTRIALI È QUELLA DEL FUNZIONAMENTO SENZA MOLLE DI BILANCIAMENTO MEDIANTE L'IMPIEGO DI UN ALBERO DI ELEVATO DIAMETRO E DI MOTORIZZAZIONI LATERALI ADATTE ANCHE ALL'USO INTENSIVO. TUTTI I MOTORIDUTTORI SONO DISPONIBILI CON FINECORSO MECCANICO O FINECORSO DIGITALE E CON MANOVRA DI SOCCORSO A MANOVELLA O A CATENA, INDISPENSABILI IN MANCANZA DI CORRENTE ELETTRICA.

LE SERRANDE DOMINUS SONO SICURE IN OGNI FASE DI APERTURA E CHIUSURA, RISPETTANDO I REQUISITI DI SICUREZZA IN OSSERVANZA DELLA NORMA UNI EN 13241:2016.

OUR INDUSTRIAL ROLLING SHUTTERS WORK WITHOUT SPRINGS WITH THE USE OF A HIGH-DIAMETER SHAFT AND SIDE MOTORIZATIONS FOR INTENSIVE USE. ALL SIDE MOTORIZATIONS ARE AVAILABLE WITH MECHANICAL LIMIT SWITCH OR DIGITAL LIMIT SWITCH AND WITH HAND CRANK OR HAND CHAIN RESCUE OPERATION, ESSENTIAL IN THE ABSENCE OF ELECTRIC CURRENT. DOMINUS ROLLING SHUTTERS ARE SAFE DURING OPENING AND CLOSING PHASE, RESPECTING SAFETY REQUIREMENTS IN COMPLIANCE WITH THE UNI EN 13241: 2016.

COMPONENTISTICA

1. Cuscinetto flangiato oscillante
2. Albero
3. Motorizzazione laterale
4. Mensole
5. Guide di scorrimento
6. Centralina elettrica
7. Cavo di collegamento
8. Sistemi di fissaggio in dotazione

COMPONENTS

1. Bearing
2. Shaft
3. Side motor
4. Endplate
5. Guides
6. Control unit
7. Connecting cable
8. Fixing system supplied

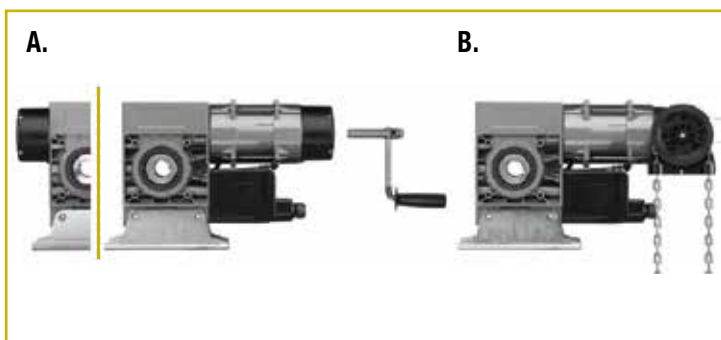

MODALITÀ D'EMERGENZA

- A. con manovella manuale d'emergenza
- B. catena manuale d'emergenza

EMERGENCY OPERATION

- A. with emergency hand crank
- B. emergency hand chain



I motori laterali possono essere a trasmissione diretta, ideale per serrande di piccole e medie dimensioni con dispositivo paracadute integrato, o con rinvio a catena, per serrande avvolgibili di grandi dimensioni e paracadute esterno. Sono disponibili due tipi di comando: a uomo presente, che obbliga il movimento della serranda solo ed esclusivamente con la pressione continuata di un pulsante a muro (posto vicino alla serranda), e quello automatico, azionato a distanza tramite telecomando. Al fine di non arrecare danni a persone e/o cose, al comando automatico è obbligatorio aggiungere dispositivi di sicurezza che bloccano il funzionamento della serranda al passaggio di persone o cose: no touch filare; no touch wireless; fotocosta wireless; barriere di fotocellule.

Side motorizations can be direct drive, ideal for small and medium sized shutters with integrated parachute, or with chain transmission, for large rolling shutters and external parachute. Two types of controls are available: dead man's switch, which requires the shutter to move only and exclusively with the continuous pressing of a wall button (located near the shutter); and the automatic one, operated remotely by remote control. In order not to damage people and / or things, it is mandatory to add safety devices to the automatic control that block the operation of the shutter when people or things pass: no touch photocell + spiral cable; no touch wireless photocell; safety edge in conductive rubber; photocells.

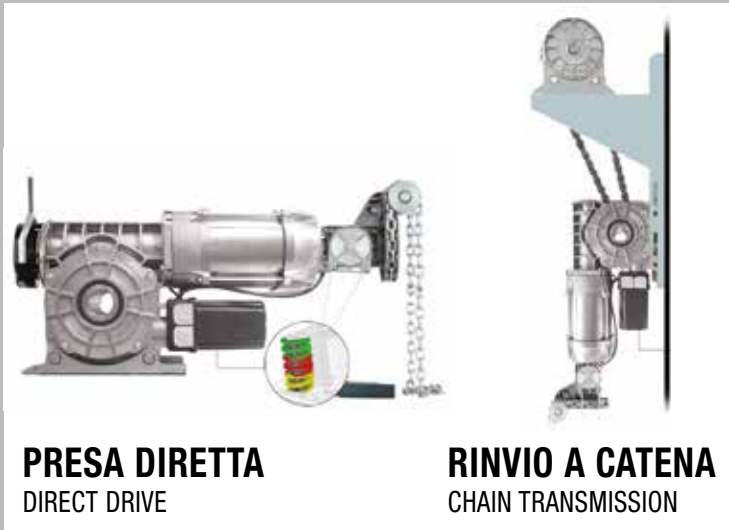

I MOTORIDUTTORI A PRESA DIRETTA SONO TUTTI CON PARACADUTE INTEGRATO, PER SERRANDE DI MEDIE DIMENSIONI. PER LE GRANDI SERRANDE INDUSTRIALI SI UTILIZZANO I MOTORI CON RINVIO A CATENA, CON I QUALI L'AZIONAMENTO DELLA SERRANDA AVVIENE TRAMITE TRASMISSIONE A CATENA.

THE DIRECT DRIVE MOTORS ARE INTEGRATED PARACHUTE, FOR MEDIUM SIZED SHUTTERS. FOR MEDIUM DIMENSION ROLLINGS. FOR LARGE INDUSTRIAL SHUTTERS, WE USE MOTORS WITH CHAIN TRANSMISSION.

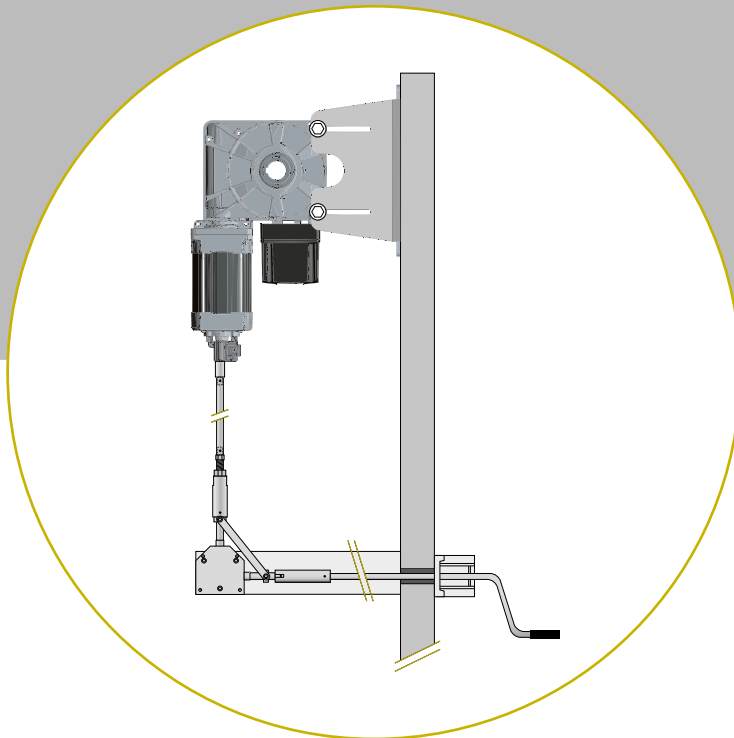

SBLOCCO MOTORE DALL'ESTERNO
MOTOR RELEASE FROM OUTSIDE

In caso di mancanza di energia elettrica permette di sbloccare il motore, consentendo l'apertura manuale del portone.

In the event of a power failure, it allows the motor to be unlocked, allowing the door to be opened manually.

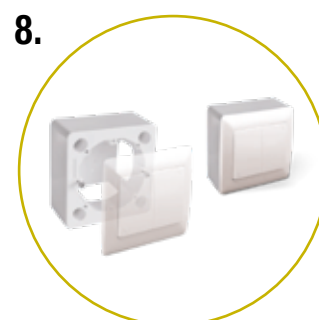

**ACCESSORIO STANDARD
PER IL KIT U.P.
STANDARD FOR U.P. KIT**

1. COD. 270168-112
Centrale di comando trifase QC300
standard per il kit uomo presente
Three-phases QC300 control unit
standard for U.P. Kit

**COD. 271634 KIT TELECOMANDATO
REMOTE CONTROLLED KIT**

2. COD. 270168-85
Lampeggiante
Flashing light

3. COD. 270168-18
Trasmittitore quadricanale
Four channels transmitter

4. COD. 270168-91
Ricevente radio
Radio receiver

**PULSANTIERE E SELETTORI
PUSHBUTTONS AND SELECTORS**

5. COD. 270168-70
Selettore da incasso con chiave
Flush mounted key selector

6. COD. 270168-11
Selettore da incasso con sportello
Flush mounted selector with key door

7. COD. 270168-8
Cassetta sblocco blindoor + pulsante Twisty
Blindoor security box with key + Twisty rotary switch

8. COD. 270168-37 / 38
Pulsantiera con supporto
Flush mounted switch with two momentary buttons



MOTORE RINVIATO SU BANDIERA
MOTOR SIDE PLATE

GLI ELETTORIDUTTORI LATERALI CON RINVIO SU BANDIERA CON CENTRALINA A BORDO POSSONO ESSERE MONOFASE O TRIFASE, ADATTI ALL'USO INTENSIVO (PER I MODELLI MINI TAURUS E TAURUS 7). CARATTERISTICA PRINCIPALE È L'INGOMBRO LATERALE DRASTICAMENTE RIDOTTO E L'ESTREMA FACILITÀ DI MANUTENZIONE E SOSTITUZIONE.

MOTORS SIDE PLATE WITH CONTROL UNIT ON BOARD CAN BE SINGLE-PHASE OR THREE-PHASE, SUITABLE FOR INTENSIVE USE (FOR MINI TAURUS AND TAURUS 7 MODELS). MAIN CHARACTERISTIC IS THE DRASTICALLY REDUCED SIDE TANK AND THE EXTREME MAINTENANCE AND REPLACEMENT.

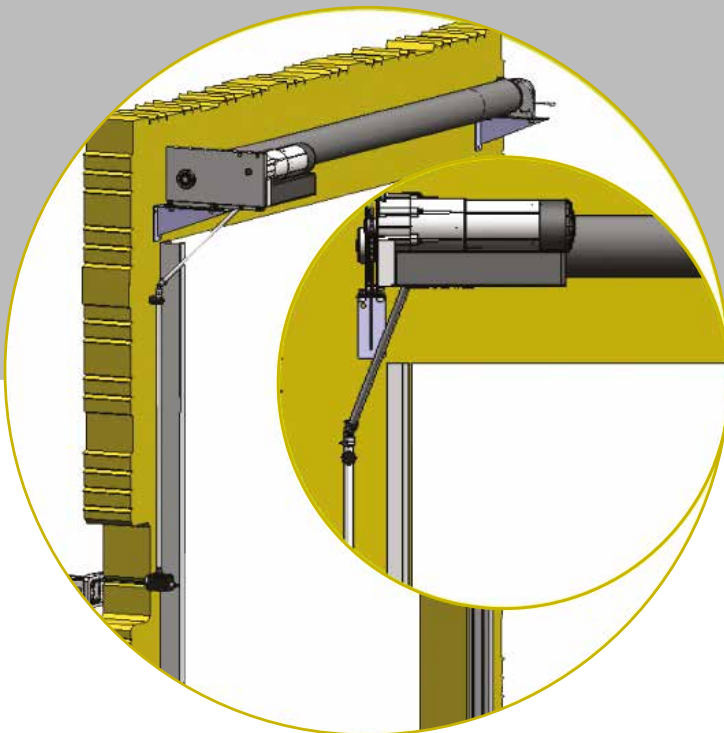

COD. 270156-71 / 75

**Kit per manovra esterna
con manovella per Taurus**
Outside motor release KIT
for Taurus model

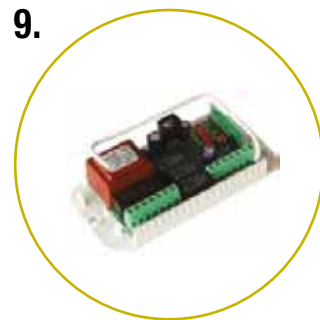
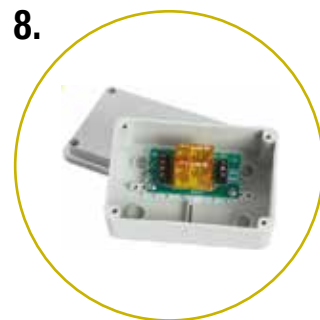
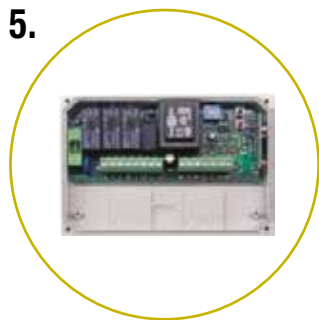
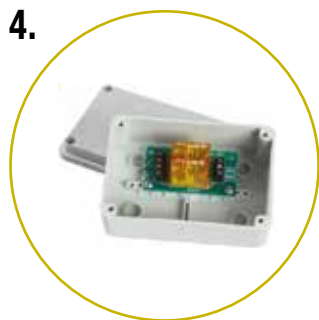

PULSANTIERE E SELETTORI
PUSHBUTTONS AND SELECTORS

1. COD. 270156-11
Selettore a chiave sovrapposto (a magazzino)
Key selector (in stock)

2. COD. 270156-49
Pulsantiera per interni a parete standard per il kit uomo presente
Switch panel standard for U.P. KIT

3. COD. 270156-84
Selettore a cilindro europeo (su ordinazione)
Key selector for outdoor (on order)

COD. 285322 KIT TELECOM. FERRARO
FERRARO REMOTE CONTROLLED KIT

4. COD. 270156-17 Modulo di interfaccia per Taurus e Minitaurus
Interface module for Taurus e Minitaurus

5. COD. 270254-26 Programmatore monofase con ricevente rolling code
Single phase programmer with rolling code receiver

6. COD. 270254-27 Trasmettitore rolling code bicanale
Two channel rolling code transmitter

7. COD. 270254-50 Lampeggiatore led giallo
Flashing yellow light

COD. 285317 KIT TELECOM. SEAV
SEAV REMOTE CONTROLLED KIT

8. COD. 270156-17 Modulo di interfaccia per Taurus e Minitaurus
Interface module for Taurus e Minitaurus

9. COD. 270254-7 Programmatore monofase con ricevente
Single phase programmer with receiver

10. COD. 270254-15 Trasmettitore rolling code bicanale RS2
Two channel rolling code transmitter RS2

11. COD. 270254-50 Lampeggiatore led giallo
Flashing yellow light



MDF

I MOTORI ESTERNI MDF DELINEANO UNA FORMA COMPATTA CHE CONSENTE LE MIGLIORI POSSIBILITÀ DI MONTAGGIO. IL DISPOSITIVO D'ARRESTO È GIÀ INTEGRATO, NON RICHIEDE MANUTENZIONE E OFFRE COSÌ LA SOLUZIONE PIÙ SICURA PER LA SERRANDA.

THE GEAR MOTORS MDF SERIES ALIGN A COMPACT FORM THAT ALLOWS THE BEST ASSEMBLY POSSIBILITIES. THE ARREST DEVICE HAS ALREADY INTEGRATED, DOES NOT REQUIRE MAINTENANCE, AND SO PROVIDES THE MOST SECURE SOLUTION FOR THE SHUTTER.



KD

LE AUTOMAZIONI PER SERRANDE DI GRANDI DIMENSIONI SONO MOTORI CON TRASMISSIONE A CATENA POTENTI PER SITUAZIONI DI MONTAGGIO PARTICOLARI.

THE AUTOMATIONS FOR BIG-SIZE SHUTTERS ARE MOTORS WITH POWER CHAIN TRANSMISSIONS FOR PARTICULAR MOUNTING SITUATIONS.

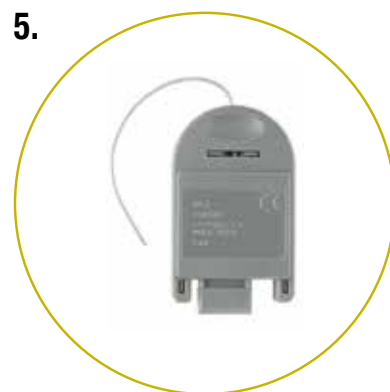
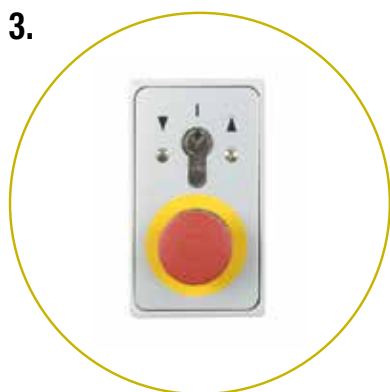

**ACCESSORIO STANDARD
PER IL KIT U.P.
STANDARD FOR U.P. KIT**

1. COD. 281701-120
Centralina trifase CS310
Three-phases CS310 control unit

**SELETTORI
KEY SWITCH**

2. COD. 281701-131
Selettore sovrapposto
Key switch surface mounted

3. COD. 281701-132
Selettore a fungo sovrapposto
Surface mounted key switch with
emergency stop button

**KIT TELECOMANDATO
REMOTE CONTROLLING KIT**

4. COD. 281701-111
Trasmittitore manuale 4 canali
Hand-held transmitter 4-channel

5. COD. 281701-112
Ricevitore a innesto
Radio receiver

6. COD. 281701-118
Lampeggiante a luce fissa
Signal light



ACCESSORI DI SICUREZZA

SAFETY ACCESSORIES

AL FINE DI NON ARRECARRE DANNI A PERSONE E COSE LA SERRANDA CON TIPOLOGIA DI COMANDO AUTOMATICO È CORREDATA DI DISPOSITIVI DI SICUREZZA AGGIUNTIVA CHE BLOCCANO ISTANTANEAMENTE IL FUNZIONAMENTO DELLA SERRANDA AL PASSAGGIO DI PERSONE O COSE, QUALI IL SISTEMA FOTOCOSTA WIRELESS, IL NO TOUCH FILARE, IL SISTEMA NO TOUCH WIRELESS E LE BARRIERE DI FOTOCELLULE.

IN ORDER TO NOT DAMAGE PEOPLE AND THINGS THE SHUTTER WITH AUTOMATIC CONTROL TYPE IS EQUIPPED WITH ADDITIONAL SAFETY DEVICES THAT IMMEDIATELY LOCK THE SHUTTER, SUCH AS THE WIRELESS OPTICAL SAFETY CONTACT STRIP, THE NO TOUCH WIRELESS SYSTEM, THE NO TOUCH WIRELESS SYSTEM AND THE PHOTOCELLS BARRIER.

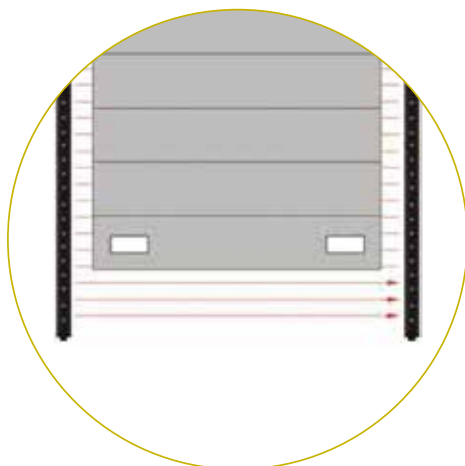

COD. 282365

BARRIERA DI FOTOCELLULE

PHOTOCELLS BARRIER

Le barriere di fotocellule garantiscono la messa in sicurezza durante i processi automatizzati, definendo un campo di protezione con elevato numero di fasci luminosi di una determinata altezza e larghezza.

The photocell barriers guarantee safety during automated processes, defining a protective field with a high number of light beams of a certain height and width.

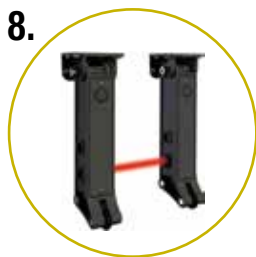

COD. 282360 / 282363

Kit Fotocosta wireless

Optical safety edge radio control Kit

- 1. COD. 270168-14 Cellula Fotoelettrica da esterno 15 m
Infra-red safety beam for wall fixing 15 m
- 2. COD. 291480-1 Alimentatore 3-12 V DC - 600mA
Power supply 3-12 V DC - 600mA
- 3. COD. 251430-2 Guarnizione EPDM
per alloggiamento ottiche H=52mm
EPDM gasket for optical edge H=52mm
- 4. COD. 270254-31 Ottiche per la fotocosta
Optical safety edge radio control
- 5. COD. 270254-33 Radioband RX3
Radioband RX3
- 5. COD. 270254-32 Radioband TX3
Radioband TX3

COD. 282361

Kit No Touch filare

No Touch wires kit

- 6. COD. 270168-14 Cellula Fotoelettrica da esterno 15 m
Infra-red safety beam for wall fixing 15 m
- 7. COD. 291480-1 Alimentatore 3-12 V DC - 600mA
Power supply 3-12 V DC - 600mA
- 8. COD. 270254-10 Fotocellula No Touch 1
No Touch 1 light barrier
- 9. COD. 270254-11 Centralina di controllo
Control unit
- 10. COD. 25200989-1 Cavo spiralato a 5 poli L 750 mm
Spiral cable 5 poles L 750 mm

COD. 282362

Kit No Touch wireless

No Touch wireless Kit

- 11. COD. 270168-14 Cellula Fotoelettrica da esterno 15 m
Infra-red safety beam for wall fixing 15 m
- 12. COD. 291480-1 Alimentatore 3-12 V DC - 600mA
Power supply 3-12 V DC - 600mA
- 13. COD. 270254-44 Fotocellula No Touch 868
No Touch 868 barrier light
- 14. COD. 270254-43 Ricevitore master 868
Receiver master 868



DOMINUS FINITURE E COLORI / FINISHES AND COLORS

Consulta il catalogo online.

Consult the online catalog.

FERRAROPORTE.COM/DOMINUS



COLORI MONOLAMIERA

SINGLE SKINNES COLOURS

LA GAMMA DI COLORI REALIZZABILE CON LA VERNICIATURA A POLVERE È PRESSOCHÉ INFINITA: LA VERNICIATURA INDUSTRIALE VI PERMETTE DI SCEGLIERE TRA LA SCALA DI COLORI RAL, UNIVERSALMENTE RICONOSCIUTA NELL'AMBITO DELLA COLORAZIONE DI VERNICI E RIVESTIMENTI.

N.B.: PER I MODELLI SFB, SFBR, SFO, SFOR, SFLUX SI SCONSIGLIA LA VERNICIATURA.

THE RANGE OF COLORS THAT CAN BE CARRIED OUT WITH POWDER PAINTING IS ALMOST INFINITE: INDUSTRIAL PAINTING ALLOWS YOU TO CHOOSE FROM THE RAL COLORS SCALE, WHICH IS UNIQUELY RECOGNIZED IN THE FIELD OF PAINTING AND COATINGS.

N.B.: FOR SFB, SFBR, SFO, SFOR, SFLUX MODELS THE PAINTING IS NOT ADVISED.

PREVERNICIATI SF - SFA A MAGAZZINO

SF - SFA PRE-PAINTED IN STOCK

Solo spessore 9/10. Lato esterno preverniciato, lato interno primer.
Only 9/10 thickness. Pre-painted exterior side, inside primer side.

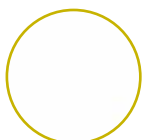

**Bianco sporco
simil RAL 9010**
Dirty white
similar to RAL 9010

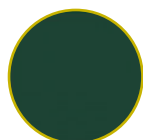

**Verde muschio
simil RAL 6005**
Moss green
similar to RAL 6005



**Testa di moro
simil RAL 8019**
Grey brown
similar to RAL 8019

PLASTIFICATO SF - SFA

SF - SFA PLASTIFICATED

Lato esterno plastificato, lato interno primer.
Plastificated exterior side, inside primer side.













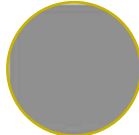

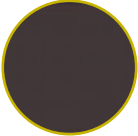

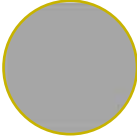
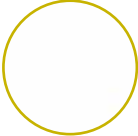

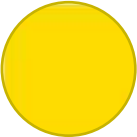



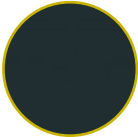
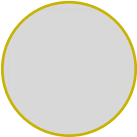

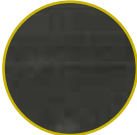
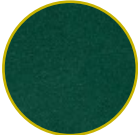
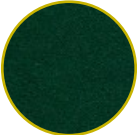
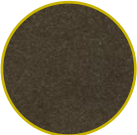

Simil rovere medio DL89E
DL89E Simil medium oak

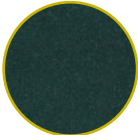
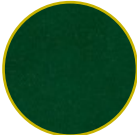
POSA ESTERNA RIPARATA
Consigliato per applicazione
delle serrande in ambienti
esterni con una limitata
esposizione al sole, pioggia e
salinità.

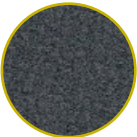

EXTERNAL POSE, COVERED
Recommended for the application
of rolling shutter in outdoor areas
with limited exposure to the sun,
rain and salinity.

VERNICIATI RAL PAINTED RAL

					
				Argento 9007 9007 Grey aluminium	Bianco perla 1013 1013 Oyster white
					
Verde muschio 6005 6005 Moss green	Testa di moro 8019 Grey brown 8019	Marrone cioccolato 8017 8017 Chocolate brown	Grigio 9006 9006 White aluminium	Bianco puro 9010 9010 Pure white	Avorio chiaro 1015 1015 Light ivory
					
Giallo navone 1021 1021 Colza yellow	Rosso 3000 3000 Flame red	Rosso 3003 3003 Ruby red	Blu genziana 5010 5010 Gentian blue	Grigio 7016 7016 Anthracite grey	Grigio 7035 7035 Light grey
					
Testa di moro Dark brown	Nero opaco Matte black	Bianco puro 9010 grinz 9010 Grinz pure white	Grigio ferro Iron grey	Verde antico Ancient green	Verde grinz Green grinz
					
Marrone antico Ancient brown	Marrone grinz Brown grinz	Grigio marmo Marble grey	Verde marmo Marble green	Rosso marmo Marble red	Marrone marmo Marble brown
					
Argento cezanne Silver cezanne	Verde modigliani Modigliani green	Nero silver Black silver	Oro van gogh Gold van gogh	Rame bugnato Copper bugnato	Mix ruggine Rust mix

I colori devono intendersi indicativi in quanto, per motivi di stampa, potrebbero discordarsi da quelli reali. I numeri riportati accanto ai colori sono da intendersi "simil RAL". Le fasce con colorazioni forti, esposte al sole, potrebbero presentare modesti spanciamenti e/o deformazioni, non soggette a contestazioni trattandosi di fenomeni del tutto naturali. Le stecche con finitura liscia possono presentare naturali ondulazioni o imperfezioni sugli snodi che non potranno essere oggetto di contestazione. Tempi di consegna da concordare.

Please, notice that printed colors are not binding since the printing process may have altered their brightness and contrast with respect to real ones. Color numbers to be intended as RAL-like. Heavy-colored, sun-exposed stecche might experience slight "spanciamento" (outward stecche bending) and/or superficial deformation. Such eventual natural occurrences cannot constitute ground for complaint. Smooth-finish stecche may present a natural waviness or imperfezioni sugli snodi which cannot constitute ground for complaint. Delivery times to be agreed.

COLORI SFDAC ACCIAIO / SFDAL ALLUMINIO

SFDAC STEEL / SFDAL ALUMINIUM
COLOURS

**POSSIBILITÀ DI SCELTA TRA UN AMPIA
GAMMA DI VERNICI A POLVERE CON
UN'OTTIMA CAPACITÀ DI RESISTENZA ALLE
CONDIZIONI ESTERNE E DI CONSERVAZIONE
DEL COLORE CHE SODDISFANO TUTTI I
MAGGIORI STANDARD ARCHITETTONICI
EUROPEI. SONO INOLTRE DISPONIBILI DUE
TINTE SIMIL LEGNO.**

YOU CAN CHOOSE FROM A WIDE RANGE OF POWDER
COATING COLOURS WITH EXCELLENT RESISTANCE
TO OUTDOOR CONDITIONS AND EXCELLENT COLOUR
RETENTION THAT MEETS THE REQUIREMENTS OF ALL
MAJOR EUROPEAN ARCHITECTURAL STANDARDS.
ALSO, TWO WOOD IMITATION PLASTICIZED COLORS
ARE AVAILABLE.

**VERNICI
ECO-SOSTENIBILI**

**ENVIRONMENT-
FRIENDLY
PAINTS**

SFDAC ACCIAIO / SFDAL ALLUMINIO VERNICIATI A POLVERE

SFDAC STEEL / SFDAL ALUMINIUM POWDER COATED



Bianco perla 1013
1013 Oyster white



Rosso fuoco 3000
3000 Red flame

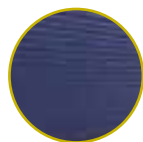

Blu genziana 5010
5010 Gentian blue



Verde muschio 6005
6005 Moss green



Grigio ardesia 7015
7015 Slate grey

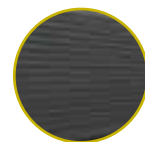

Grigio antracite 7016
7016 Anthracite grey



Marrone seppia 8014
8014 Sepia brown



Marrone cioccolato 8017
8017 Chocolate brown



Bianco grigio 9002
9002 Grey white



Bianco alluminio 9006
9006 White aluminium

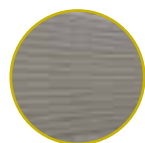

Grigio alluminio 9007
9007 Grey aluminium



Bianco traffico 9016
9016 Traffic white

SFDAC ACCIAIO VERNICIATI A POLVERE

SFDAC STEEL POWDER COATED



Rovere Dorato
Golden Oak



Rovere Scuro
Dark Oak

SFDAC ACCIAIO ZINCATO

SFDAC STEEL GALVANIZED

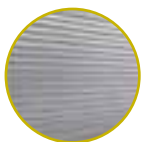

Zincato
Galvanized

I colori devono intendersi indicativi in quanto, per motivi di stampa, potrebbero discordarsi da quelli reali. I numeri riportati accanto ai colori sono da intendersi "simil RAL". Le fasce con colorazioni forti, esposte al sole, potrebbero presentare modesti spanciamenti e/o deformazioni, non soggette a contestazioni trattandosi di fenomeni del tutto naturali.

Please, notice that printed colors are not binding since the printing process may have altered their brightness and contrast with respect to real ones. Color numbers to be intended as RAL-like. Heavy-colored, sun-exposed stecche might experience slight "spanciamiento" (outward stecche bending) and/or superficial deformation. Such eventual natural occurrences cannot constitute ground for complaint.

COLORI SFEAC ACCIAIO
SFEAC STEEL COLOURS

COLORI SFEAL ALLUMINIO
SFEAL ALUMINIUM COLOURS

**VASTA GAMMA
DI COLORI**

**WIDE RANGE
OF COLORS**

TINTA UNITA

SOLID COLOR

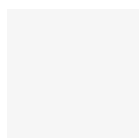

Bianco 9010
9010 White

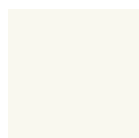

Bianco perla 1013
1013 Pearl white



Grigio 7035
7035 Grey



Grigio chiaro
Light grey



Argento
Silver



Verde scuro
Dark green



Rosso mattone
Brick red



Testa di moro
Dark Brown

RAFFAELLO

RAFFAELLO



Testa di moro Raffaello
Raffaello Dark Brown



Rosso Raffaello
Raffaello red



Grigio Raffaello
Raffaello grey



Verde Raffaello
Raffaello green

SIMIL LEGNO

IMITATION WOOD



Legno scuro
Dark wood



Legno noce
Walnut wood



Legno castagno
Chestnut wood

TINTA UNITA

SOLID COLOR

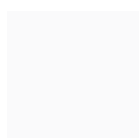

Bianco
White



Grigio chiaro
Light grey



Testa di moro
Grey brown



***Argento**
Silver

FINTO LEGNO

IMITATION WOOD

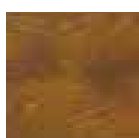

Legno castagno
Chestnut wood



***Aavorio 1013**
1013 Ivory

**I colori devono intendersi indicativi in quanto, per motivi di stampa, potrebbero discordarsi da quelli reali.
I numeri riportati accanto ai colori sono da intendersi "simil RAL". * A richiesta.**

Please, notice that printed colors are not binding since the printing process may have altered their brightness and contrast with respect to real ones.
Color numbers to be intended as RAL-like. * On request.



DOMINUS DISEGNI / TECHNICAL DRAWINGS

Consulta il catalogo online.

Consult the online catalog.

FERRAROPORTE.COM/DOMINUS



DISEGNI LIVING

LIVING TECHNICAL DRAWINGS

MONTAGGIO IN LUCE

APPLICATION BETWEEN THE WALL

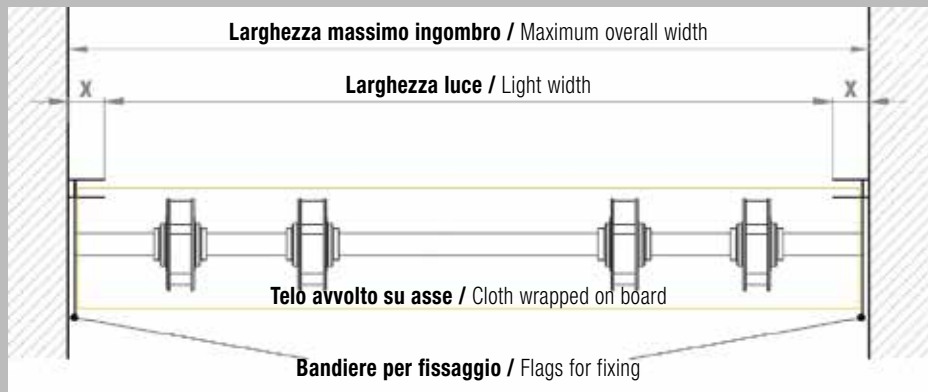

Fissaggio con staffe per montaggio in massimo ingombro, per lasciare lo spazio necessario all'apertura bandiere: fare attenzione che ci siano almeno 20 mm per lato.

Fixing with mounting brackets in maximum dimensions, to leave the space necessary for the opening of the flags: make sure there is at least 20 mm on each side.

MONTAGGIO DIETRO MAZZETTA

APPLICATION BEHIND THE WALL



Fissaggio guide standard con tasselli e/o zanche; fissaggio con staffe a richiesta

Fastening standard guides with dowels and / or clamps; fixing with brackets on request

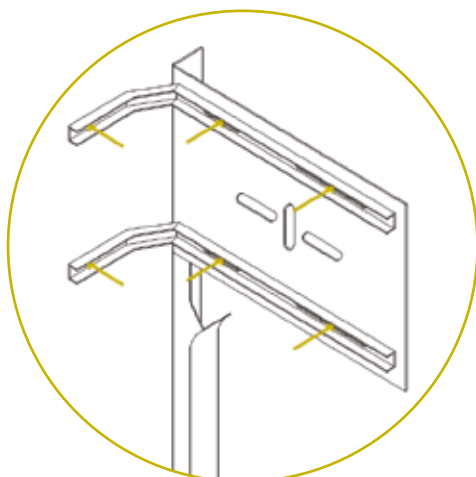

TIPOLOGIA DI FISSAGGIO BANDIERA CON STAFFE

PLATE ATTACHMENT TYPE
WITH GUIDE SUPPORTS

NOTE

X Dimensione variabile in funzione della guida (nel disegno è rappresentata una guida a U) e dello spazio necessario all'apertura bandiere (almeno 20 mm per lato)

X Variable size according to the guide (in the drawing it is a U-shaped guide) and the space necessary to open the brackets (at least 20 mm per side)

MONTAGGIO DIETRO MAZZETTA

APPLICATION BEHIND THE WALL

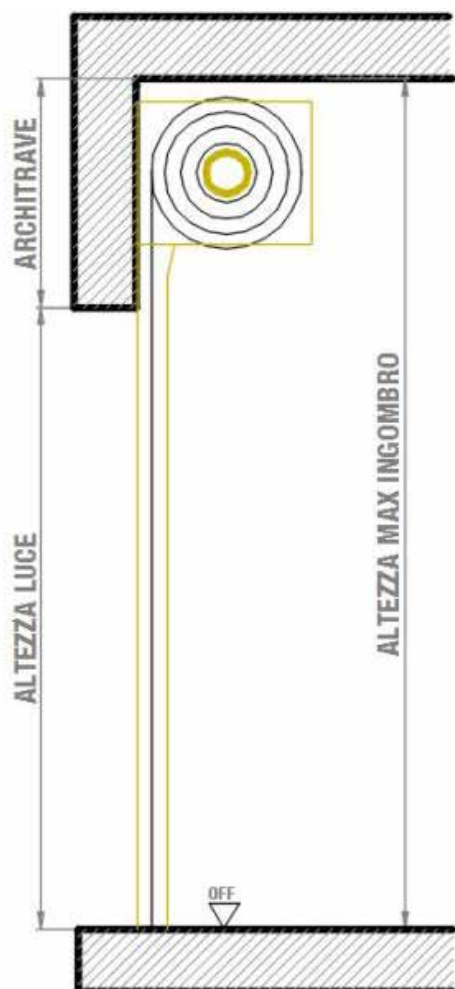

MONTAGGIO IN LUCE

APPLICATION BETWEEN THE WALL

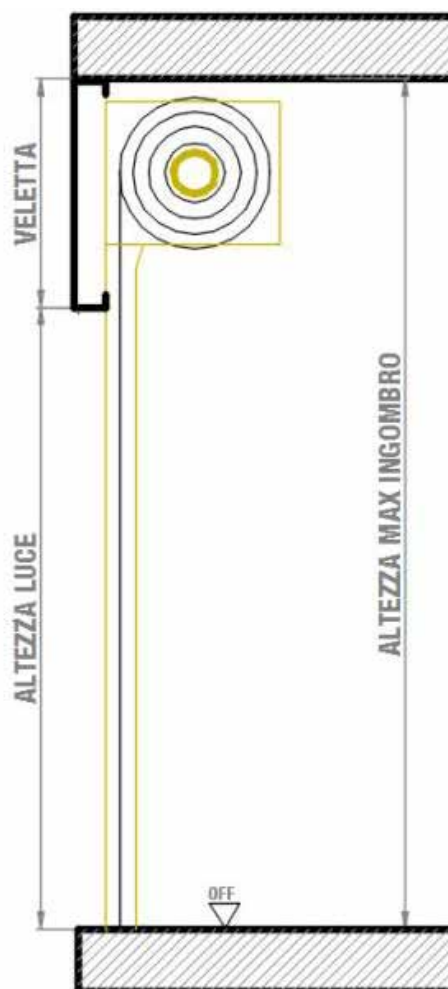

LIVING

RESIDENTIAL DOORS

NOTE

ARCHITRAVE/VELETTA Dimensione variabile in funzione dell'altezza e della tipologia di serranda. Per gli ingombri delle architravi consultare il listino.

LINTEL/UPPER COVER Variable size according to the height and type of damper. For the lintels of the lintels consult the price list.

DISEGNI TIME

TIME TECHNICAL DRAWINGS

MONTAGGIO IN LUCE

OPENING ASSEMBLY

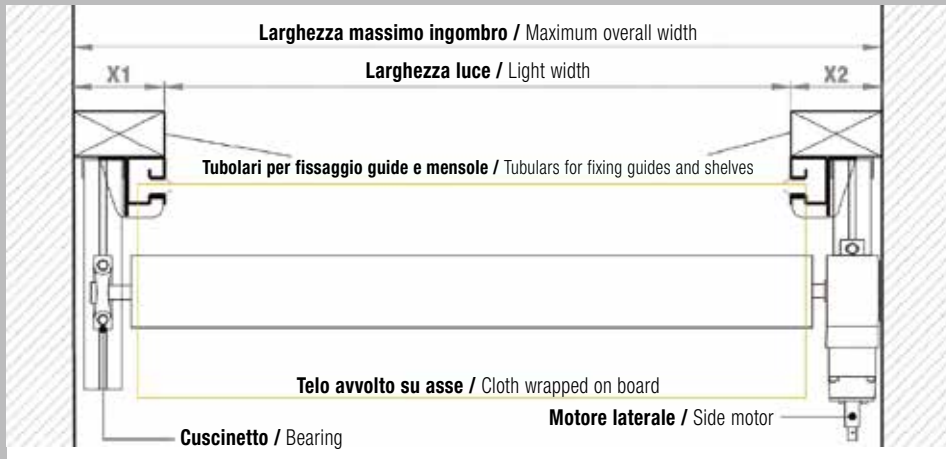

MONTAGGIO DIETRO MAZZETTA

APPLICATION BEHIND THE WALL

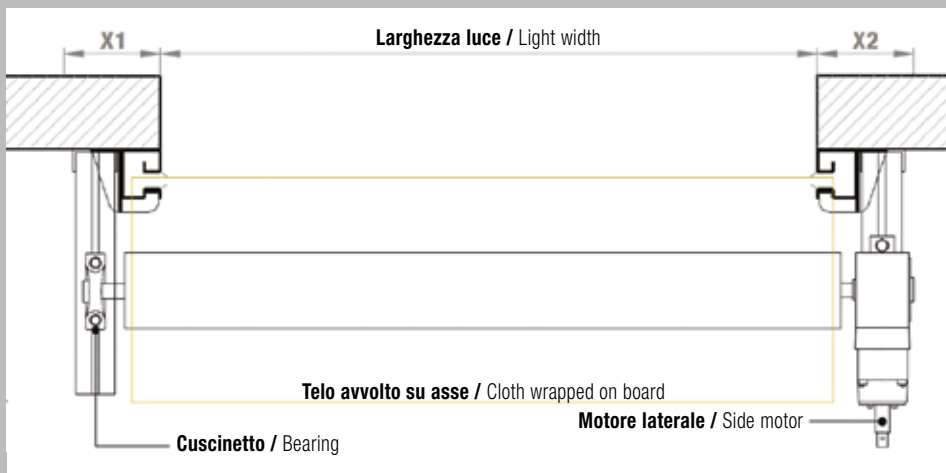

APPLICAZIONE STAFFA PER GUIDA DIETRO MAZZETTA

GUIDE SUPPORTS
INSTALLED BEHIND THE WALL

NOTE

X1 / X2: Dimensione variabile in funzione della guida (nel disegno è rappresentata una guida G80) e del motore scelto. Per gli ingombri consultare il listino.

X1 / X2: Variable size according to the guide (in the drawing a G80 guide) and the chosen motor. For the lintels consult the price list.

MONTAGGIO DIETRO MAZZETTA

APPLICATION BEHIND THE WALL

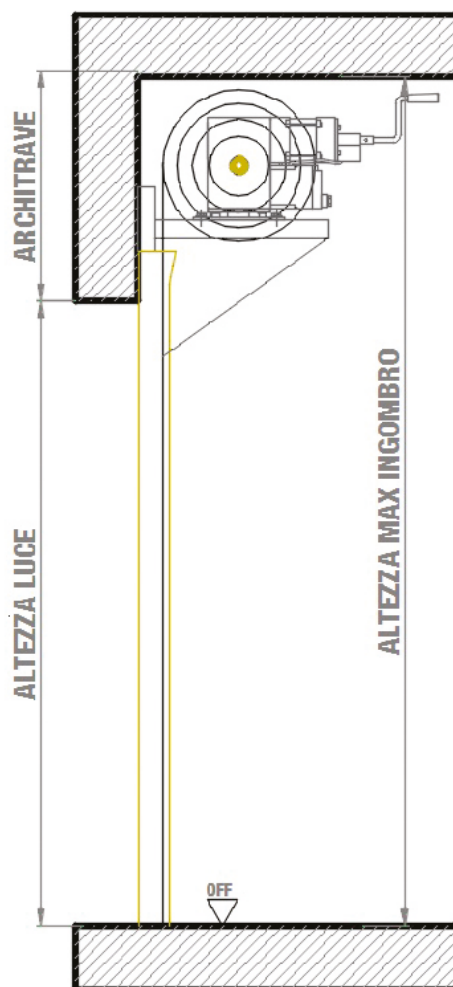

MONTAGGIO IN LUCE

APPLICATION BETWEEN THE WALL

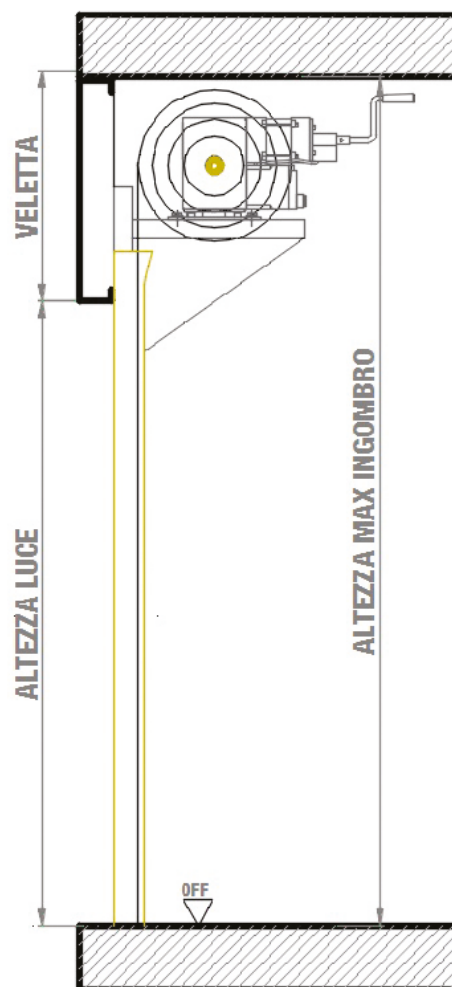

TIME

INDUSTRIAL DOORS

NOTE

ARCHITRAVE/VELETTA Dimensione variabile in funzione dell'altezza e della tipologia di serranda.

Per gli ingombri delle architravi consultare il listino.

LINTEL/UPPER COVER Variable size based on height and type of shutter.
For the lintels consult the price list.



DOMINUS ARMONIUM

Consulta il catalogo online.

Consult the online catalog.

[FERRAROPORTE.COM/DOMINUS](https://www.ferraroporte.com/dominus)



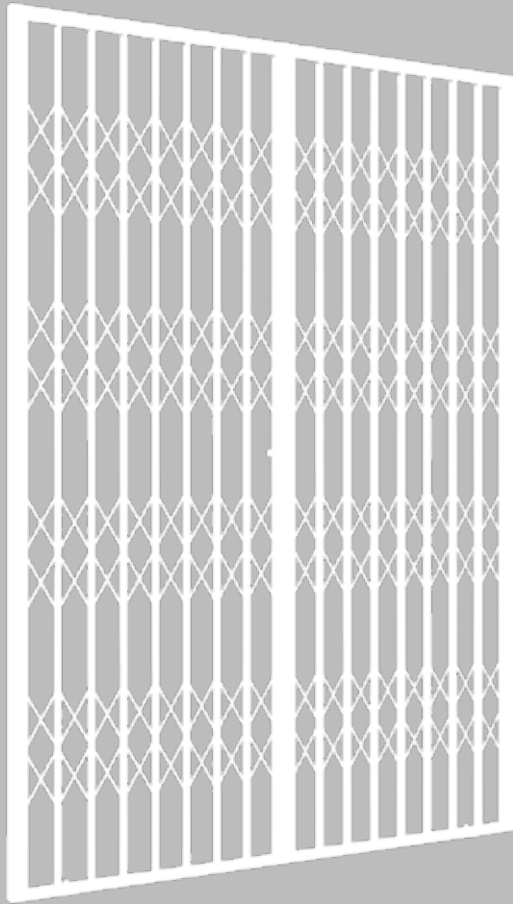

ARMONIUM CANCELLETTI RIDUCIBILI

REDUCIBLE GATES

IL CANCELLETTO ARMONIUM CF È IMPIEGATO PER LA PROTEZIONE DI VETRINE DI NEGOZI E DI FINESTRE, DOVE NON È PREVISTO LO SPAZIO PER L'AVVOLGIMENTO DI UNA SERRANDA TRADIZIONALE. INTERAMENTE COSTRUITO IN ACCIAIO ZINCATO, AD UNA O DUE ANTE, I DOPPI PROFILI AD U DA MM 15*15*15 SONO COLLEGATI DA DIAGONALI PROFILATE E STAMPATE. LO SCORRIMENTO IN ALTO CON CARRUCOLE A DOPPIO CUSCINETTO PERMETTE UN FUNZIONAMENTO FACILE E SILENZIOSO. A RICHIESTA È POSSIBILE VERNICIARE IL CANCELLETTO: PER I COLORI DISPONIBILI CONSULTARE PAGINA 96.

THE "ARMONIUM CF" GATE IS USED FOR THE PROTECTION OF SHOWCASES AND WINDOWS OF SHOP, WHERE THERE IS NO SPACE FOR A TRADITIONAL SHUTTER. ENTIRELY BUILT IN GALVANIZED STEEL, WITH ONE OR TWO LEAVES, WITH DOUBLE U PROFILES 15 * 15 * 15 MM, CONNECTED BY PROFILED AND PRINTED DIAGONALS. SLIDES WITH DOUBLE BEARING PULLEYS FOR EASY AND QUIET OPERATION. ON REQUEST IT'S POSSIBLE PAINT THE GATE: FOR AVAILABLE COLORS PLEASE SEE PAGE 96.

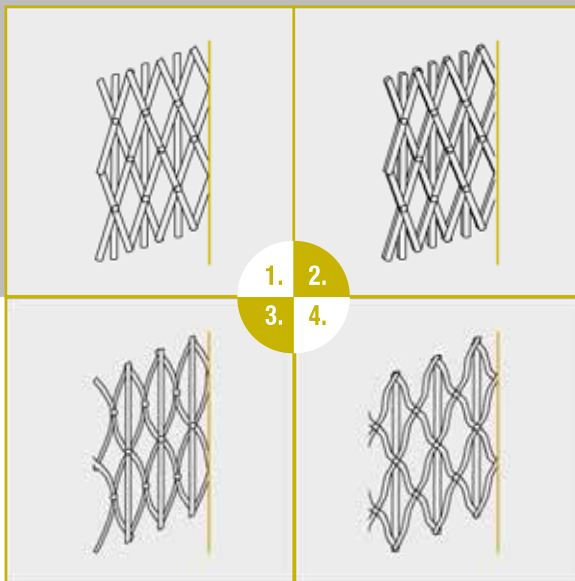

MODELLI MODELS

1. COD. A21CR CFU Semplice
2. COD. A21CR1025 CFU doppio pantografo
3. COD. A21CRA1037 CFA curva Europa
4. COD. A21CRB1037 CFB Oriente a S

SOLUZIONI DI APERTURA

OPENING SOLUTIONS

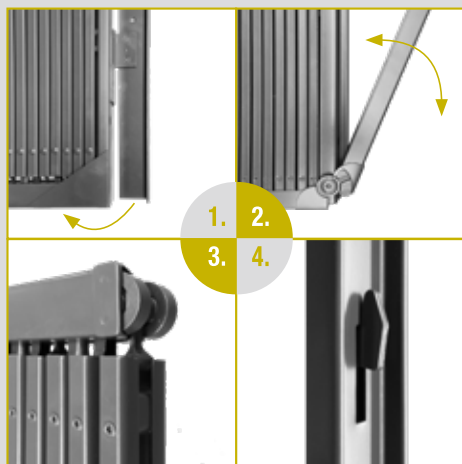
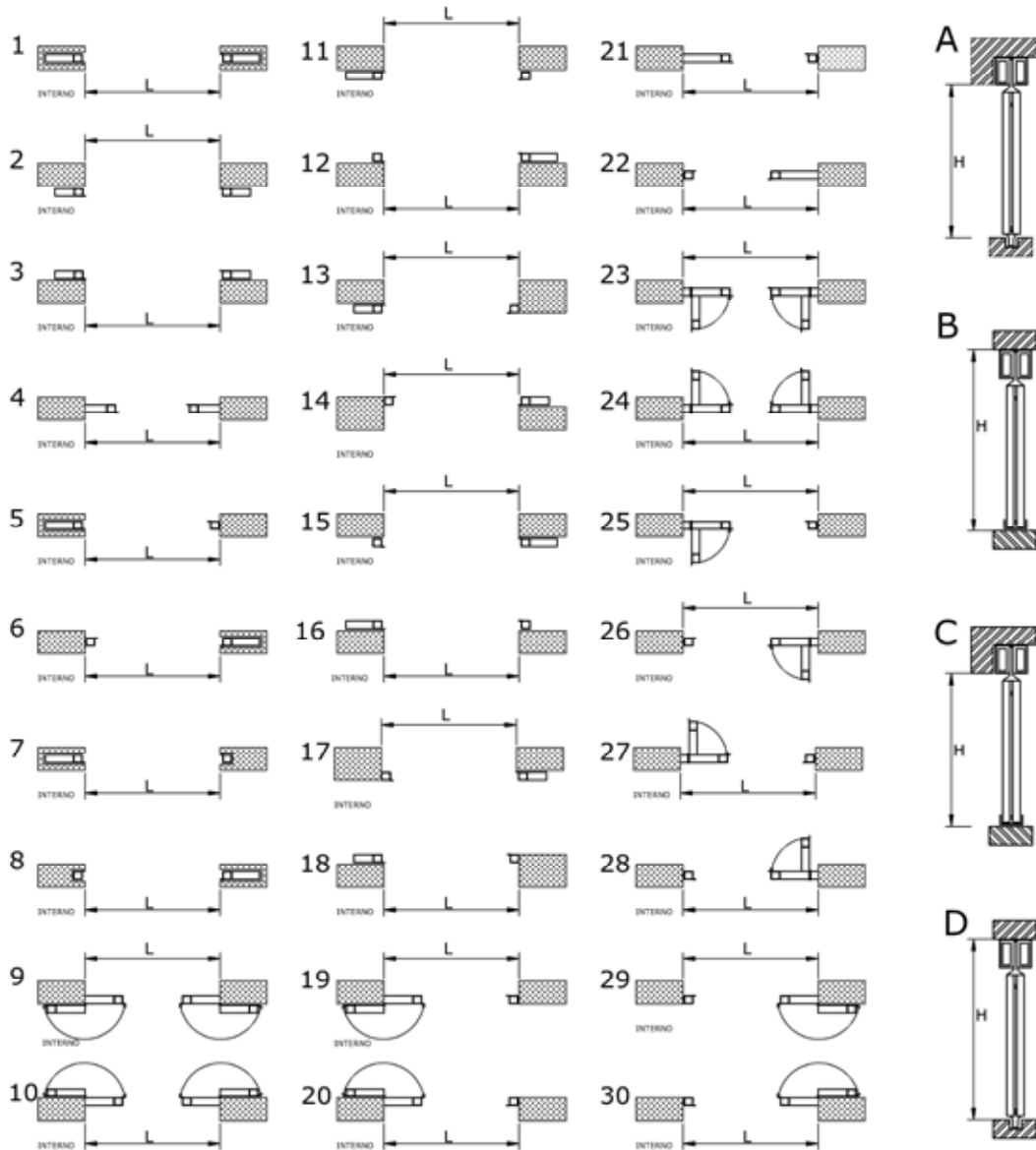

OPTIONALS

1. Anta girevole fino a 180° (optional)
2. Guida inferiore ribaltabile (optional)
3. Guida superiore in profilo "C" con cuscinetti di scorrimenti
4. Serratura a due o quattro punti di chiusura

1. Swivel door up to 180° (optional)
2. Lower folding guide (optional)
3. Upper guide in profile "C" with sliding bearings
4. Lock with two or four closing points

**MANUTENDOOR È UN MARCHIO FERRARO.
OFFRE AL MERCATO NAZIONALE SERVIZI DI
MANUTENZIONE E RIPARAZIONE PROFESSIONALI NEL
SETTORE DELLE CHIUSURE RESIDENZIALI ED INDUSTRIALI
E DEI SISTEMI PER PUNTI DI CARICO.**

Norme di riferimento: D. Lgs. 81/08 e UNI 11473.

**La rete nazionale dei Tecnici Manutendoor e la loro
formazione tecnica sono per i Clienti la garanzia di un
servizio efficiente e sempre in linea con le necessità
operative. Manutendoor assicura la disponibilità delle
parti di ricambio dei principali Produttori nazionali
ed esteri e l'aggiornamento continuo sulla normativa
nazionale ed europea dei prodotti assistiti.**

**MANUTENDOOR IS A FERRARO TRADE MARK.
IT OFFERS TO THE NATIONAL MARKET A PROFESSIONAL
MAINTENANCE AND REPAIR SERVICES IN THE FIELD OF
RESIDENTIAL AND INDUSTRIAL CLOSURES AND LOADING
POINT SYSTEMS: D. Lgs. 81/08 AND UNI 11473.**

The National network of technicians Manutendoor and their knowledge are, for the customers, a guarantee of efficient service in line with the company needs. Manutendoor assures the availability of the spare parts of the main producers and the continuous updating on the national and European standards of the treated products.



I prodotti Ferraro Group srl sono conformi alla normativa europea C€ in materia di chiusure. Per ulteriori informazioni si prega di contattare i nostri uffici tecnici.

Ferraro Group SRL products are in conformity with european regulations C€ regarding closures. For further information please contact our technical offices.

**FERRARO GRUOUP SRL
S.S. 90 DELLE PUGLIE KM 33
C.DA CAMPOREALE, ZONA P.I.P.
83031 ARIANO IRPINO (AV) IT
+39 0825 881321
info@ferraroporte.com
www.ferraroporte.com**

SISTEMA DI GESTIONE
QUALITÀ CERTIFICATO

CQY
CERTIQUALITY

UNI EN ISO 9001:2015

Associata



**MADE IN
ITALY**

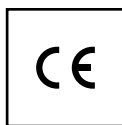

La Ferraro Group srl, si riserva il diritto di modificare le caratteristiche senza preavviso. Tutte le informazioni e i colori contenuti sono da considerarsi indicativi, non vincolanti e non costituiscono offerta di prodotto. Tutte le misure sintendono in mm.
Copyright © Ferraro Group srl, All rights reserved.

Ferraro Group srl reserves the right to change the characteristics without notice. All the information and the colors contained are to be considered indicative, not binding and do not constitute product offer. All measures are in mm. Copyright © Ferraro Group srl, All rights reserved.

